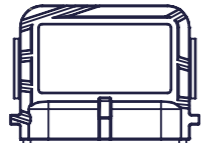

MOTOR TYPE	EA-193-80-10A+		ENCODER:	SUPERSEAL 1.5 SOCKET	CUSTOMER APPROVAL:
VOLTAGE	VDC	48	 <p>PIN 1 : 5V PIN 2 : TEMP PIN 3 : SIN PIN 4 : COS PIN 5 : GND PIN 6 : SHIELD</p>	MATING PLUG P/N:	NAME:
IEC DUTY	S2	60		282090-1	DATE:
RATED POWER	KW	10		MATING PIN P/N:	SIGNED:
RATED SPEED	RPM	4000		183035-1	
RATED FREQ.	HZ	333			
IP RATING*	IP	65			
INSUL. CLASS	-	200			
SENSOR CYCLES	CPR	5			
TEMP SENSOR	PT1000	CLASS B			

NOTES:

- KEYWAY DIMENSIONS TO ISO/R773
- SHAFT ROTATES CW, WHEN VIEWED FROM DRIVE END, WHEN COSINE SIGNAL LEADS SINE SIGNAL BY 90 DEGREES
- SHAFT ROTATES CW, WHEN VIEWED FROM DRIVE END, WHEN U-V-W WIRED PER DIAGRAM
- TERMINAL NUTS: TORQUE TO 15Nm
- SEE MANUAL FOR RECOMMENDED TORQUE VALUES OF MOTOR FASTENERS
- ESTIMATED ROTATIONAL MOMENT OF INERTIA: 11043 kg/mm<sup>2</sup>
- \* IP RATINGS - SEE USER MANUAL FOR FURTHER DETAILS

REV	CHANGE REF	DESCRIPTION	DRAWN BY	CHECKED	APPROVED	DATE
1	ECN069	PRODUCTION RELEASE	EB	SD	SD	23/05/2025

TITLE: **193-080-10A+, STD, 24MM KEYED, 48V, IP65**

DWG NO. **2019-002-065** REV **1** SCALE **1:2**

**electrified** motors

ELECTRIFIED AUTOMATION LTD,  
UNIT 4 BEECH BUSINESS PARK,  
BRIDGWATER,  
SOMERSET, TA6 4FF, UNITED KINGDOM

©2025 ELECTRIFIED AUTOMATION LTD.  
REPRODUCTION OR TRANSMISSION OF DATA HEREIN IS  
FORBIDDEN WITHOUT WRITTEN PERMISSION FROM  
ELECTRIFIED AUTOMATION LTD.

STRICTLY NO DEVIATION FROM  
DRAWING PERMISSABLE WITHOUT  
APPROVED CONCESSION FROM  
ELECTRIFIED AUTOMATION

IF IN DOUBT - ASK  
ALL DIMENSION IN MM  
CONFORMS TO BS8888

DOCUMENT TYPE	DOCUMENT STATUS	SHEET
ASSEMBLY DRAWING	PRODUCTION APPROVED	1 OF 2

**A3**

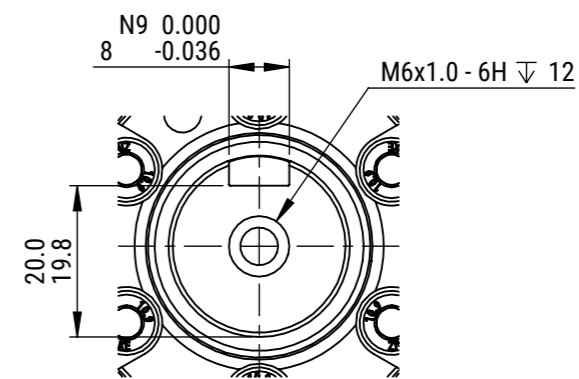
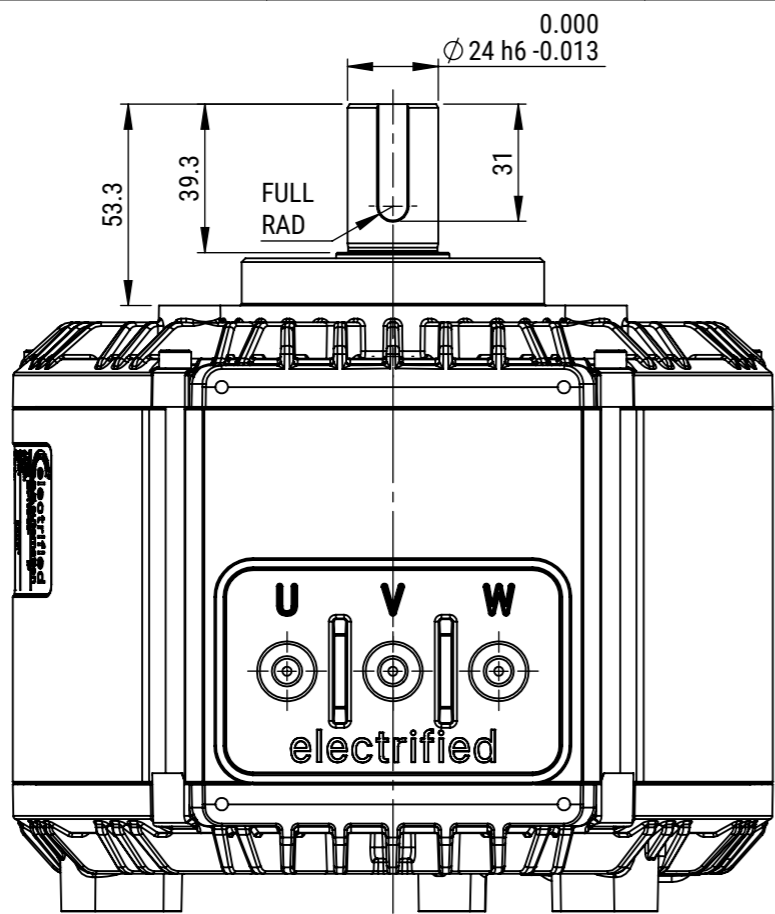

DETAIL A  
SCALE 1 : 1

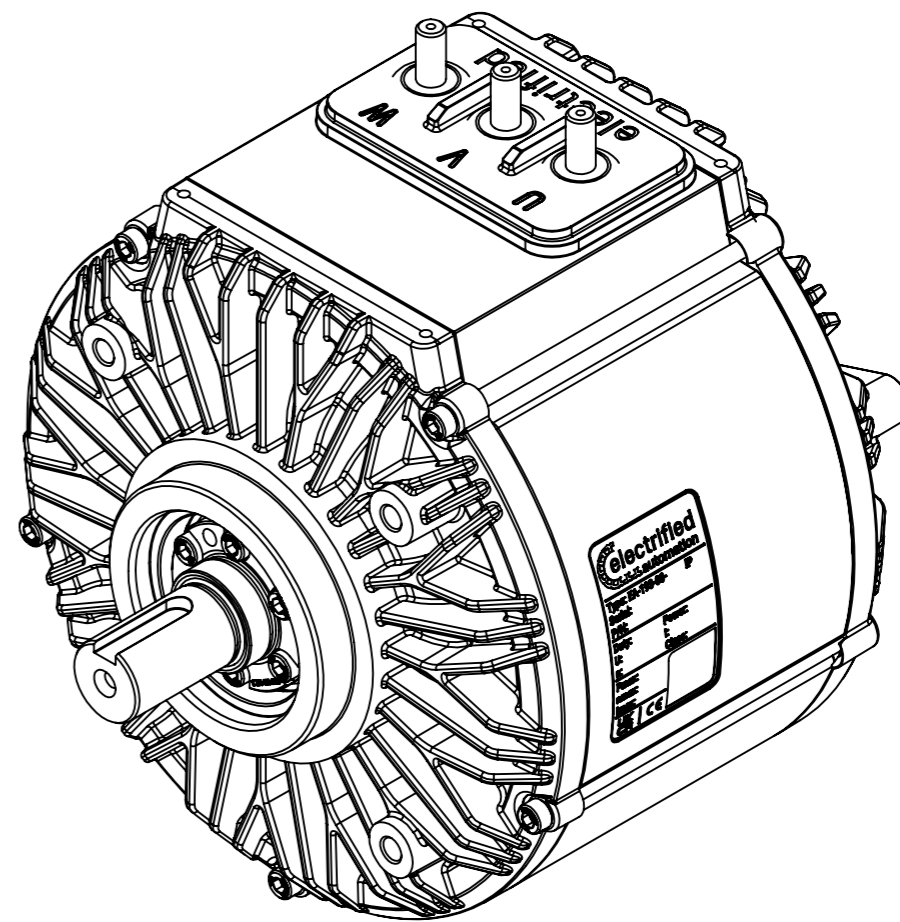
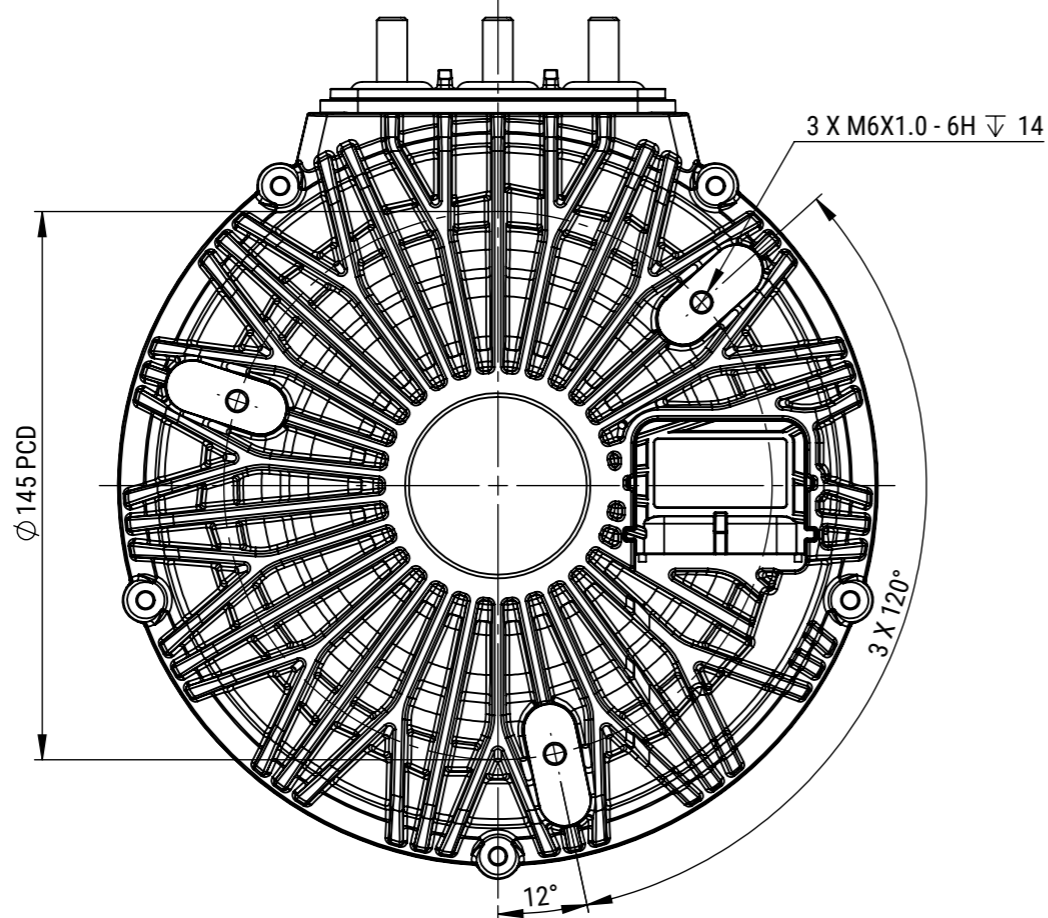

ISOMETRIC VIEW

REV	CHANGE REF	DESCRIPTION	DRAWN BY	CHECKED	APPROVED	DATE
1	ECN069	PRODUCTION RELEASE	EB	SD	SD	23/05/2025

<b>TITLE:</b> <b>193-080-10A+, STD, 24MM</b> <b>KEYED, 48V, IP65</b>						
<b>DWG NO.</b> 2019-002-065		<b>REV</b> 1	<b>SCALE</b> 1:2	<b>MASS (APPROX.)</b> 18.51kg		

ELECTRIFIED AUTOMATION LTD,  
 UNIT 4 BEECH BUSINESS PARK,  
 BRIDGWATER,  
 SOMERSET, TA6 4FF, UNITED KINGDOM

IF IN DOUBT - ASK  
 ALL DIMENSION IN MM  
 CONFORMS TO BS8888

©2025 ELECTRIFIED AUTOMATION LTD.  
 REPRODUCTION OR TRANSMISSION OF DATA HEREIN IS  
 FORBIDDEN WITHOUT WRITTEN PERMISSION FROM  
 ELECTRIFIED AUTOMATION LTD.

**DOCUMENT TYPE**  
 ASSEMBLY  
 DRAWING

**DOCUMENT STATUS**  
 PRODUCTION  
 APPROVED

STRICTLY NO DEVIATION FROM  
 DRAWING PERMISSABLE WITHOUT  
 APPROVED CONCESSION FROM  
 ELECTRIFIED AUTOMATION

**SHEET**  
 2 OF 2

**A3**