

INTERNAL INVOLUTE SPLINE DATA			
SPEC:	ANSI B92.1 1996		
SPLINE TYPE :	FILLET ROOT / SIDE FIT		
CLASS			5
NUMBER OF TEETH			19
SPLINE PITCH			24/48
PRESSURE ANGLE		°	45
BASE DIAMETER	MM	14.219	REF
PITCH DIMETER	MM	20.108	REF
MAJOR DIAMETER	MM	21.819	MAX
FORM DIAMETER	MM	21.285	
MINOR DIAMETER	MM	19.609	
		19.482	
MIN. EFF. CIRC. SPACE WIDTH (Sv)		1.875	
MAX. ACTUAL. SPACE WIDTH (Sv)	MM	1.941	
MEASUREMENT BETWEEN PINS	MM	17.054	
		17.005	
PIN DIAMETER	MM	2.032	

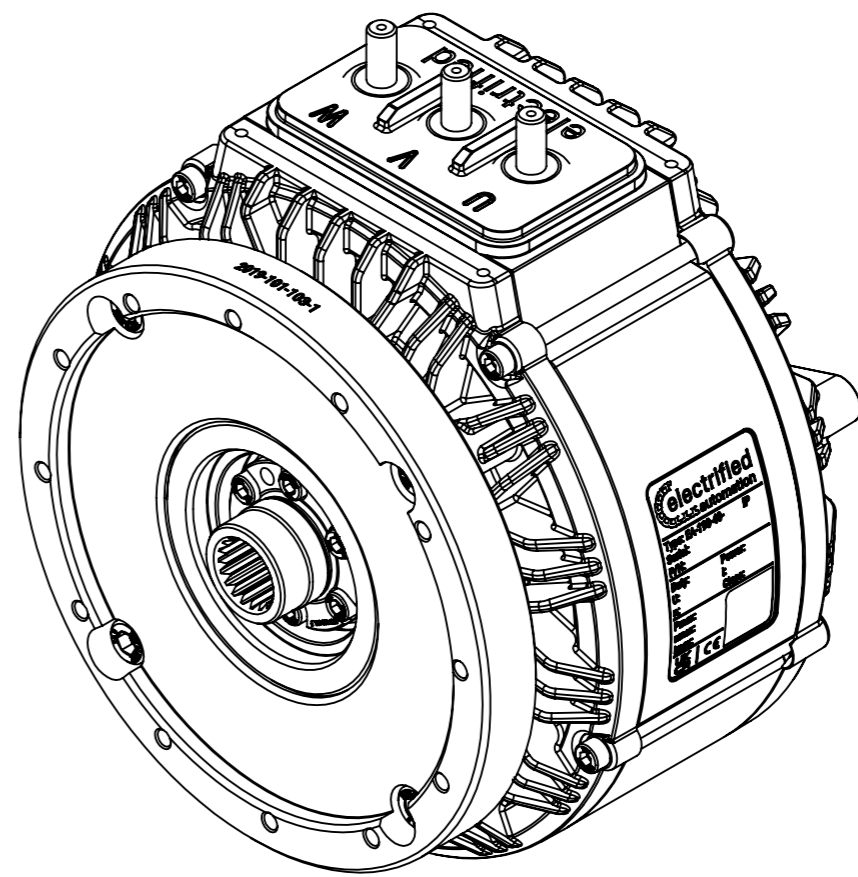
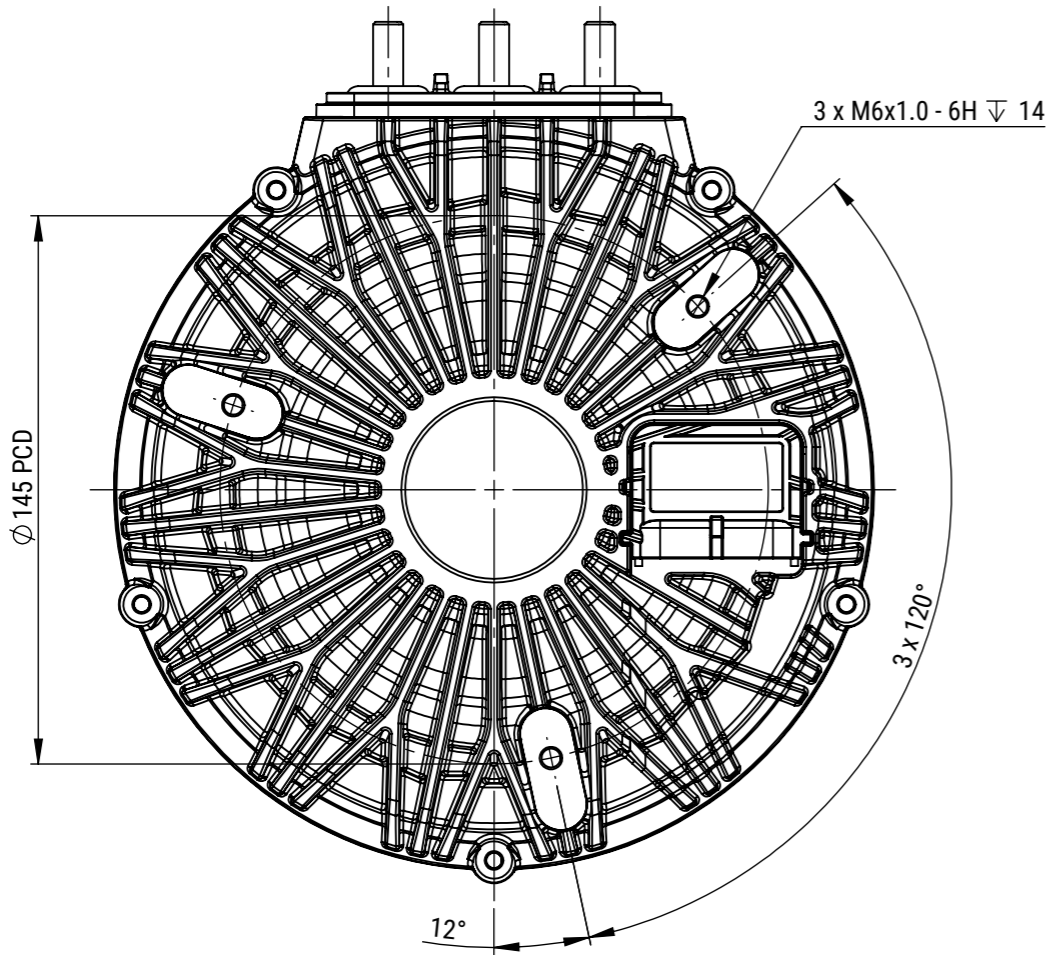

ISOMETRIC VIEW

REV	CHANGE REF	DESCRIPTION	DRAWN BY	CHECKED	APPROVED	DATE
1	ECN069	PRODUCTION RELEASE	EB	SD	SD	28/05/2025

TITLE:  
**193-040-18A+, E-AXLE 1,  
48V, IP65**

DWG NO.  
**2019-002-069**

REV  
**1**

SCALE  
**1:2**

MASS  
(APPROX.)  
**11.98kg**



ELECTRIFIED AUTOMATION LTD,  
UNIT 4 BEECH BUSINESS PARK,  
BRIDGWATER,  
SOMERSET, TA6 4FF, UNITED KINGDOM

©2025 ELECTRIFIED AUTOMATION LTD.  
REPRODUCTION OR TRANSMISSION OF DATA HEREIN IS  
FORBIDDEN WITHOUT WRITTEN PERMISSION FROM  
ELECTRIFIED AUTOMATION LTD.

STRICTLY NO DEVIATION FROM  
DRAWING PERMISSABLE WITHOUT  
APPROVED CONCESSION FROM  
ELECTRIFIED AUTOMATION

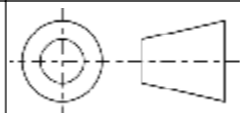

IF IN DOUBT - ASK  
ALL DIMENSION IN MM  
CONFORMS TO BS8888

DOCUMENT TYPE <b>ASSEMBLY DRAWING</b>	DOCUMENT STATUS <b>PRODUCTION APPROVED</b>	SHEET <b>2 OF 2</b>	<b>A3</b>
--	---	------------------------	-----------