

MOTOR TYPE	EA-193-80-10A+	
VOLTAGE	VDC	48
IEC DUTY	S2	60
RATED POWER	KW	10
RATED SPEED	RPM	4000
RATED FREQ.	HZ	333
IP RATING*	IP	6X
INSUL. CLASS	-	200
SENSOR CYCLES	CPR	5
TEMP SENSOR	PT1000	CLASS B

ENCODER:

SUPERSEAL 1.5 SOCKET

CUSTOMER APPROVAL:

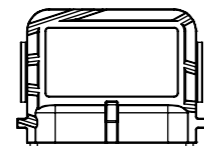

MATING PLUG P/N:
282090-1

NAME:

DATE:

SIGNED:

MATING PIN P/N:
183035-1

PIN 1: 5V
PIN 2: TEMP
PIN 3: SIN
PIN 4: COS
PIN 5: GND
PIN 6: SHIELD

NOTES:

- SHAFT ROTATES CW, WHEN VIEWED FROM DRIVE END, WHEN COSINE SIGNAL LEADS SINE SIGNAL BY 90 DEGREES
- SHAFT ROTATES CW, WHEN VIEWED FROM DRIVE END, WHEN U-V-W WIRED PER DIAGRAM
- TERMINAL NUTS: TORQUE TO 15Nm
- SEE MANUAL FOR RECOMMENDED TORQUE VALUES OF MOTOR FASTENERS
- ESTIMATED ROTATIONAL MOMENT OF INERTIA: 10971 kg/mm²
- * IP RATINGS - SEE USER MANUAL FOR FURTHER DETAILS

REV	CHANGE REF	DESCRIPTION	DRAWN BY	CHECKED	APPROVED	DATE
1	ECN069	PRODUCTION APPROVED	EB	SD	SD	28/05/2025

TITLE: **193-080-10A+, NO INTERFACE, 48V, IP6X**



ELECTRIFIED AUTOMATION LTD,
UNIT 4 BEECH BUSINESS PARK,
BRIDGWATER,
SOMERSET, TA6 4FF, UNITED KINGDOM

©2025 ELECTRIFIED AUTOMATION LTD.
REPRODUCTION OR TRANSMISSION OF DATA HEREIN IS
FORBIDDEN WITHOUT WRITTEN PERMISSION FROM
ELECTRIFIED AUTOMATION LTD.

STRICTLY NO DEVIATION FROM
DRAWING PERMISSABLE WITHOUT
APPROVED CONCESSION FROM
ELECTRIFIED AUTOMATION

DWG NO.	REV	SCALE	MASS (APPROX.)
2019-002-080	1	1:2	18.06kg



IF IN DOUBT - ASK
ALL DIMENSION IN MM
CONFORMS TO BS8888

DOCUMENT TYPE	DOCUMENT STATUS	SHEET
ASSEMBLY DRAWING	PRODUCTION APPROVED	1 OF 2

A3

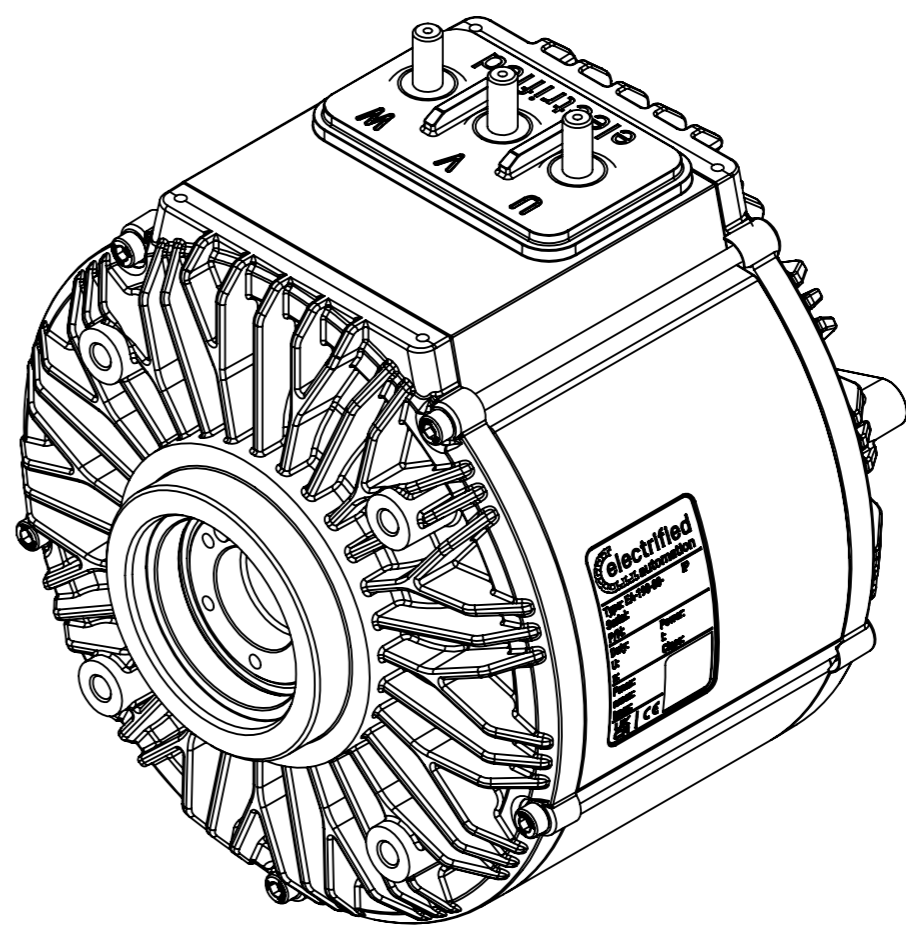
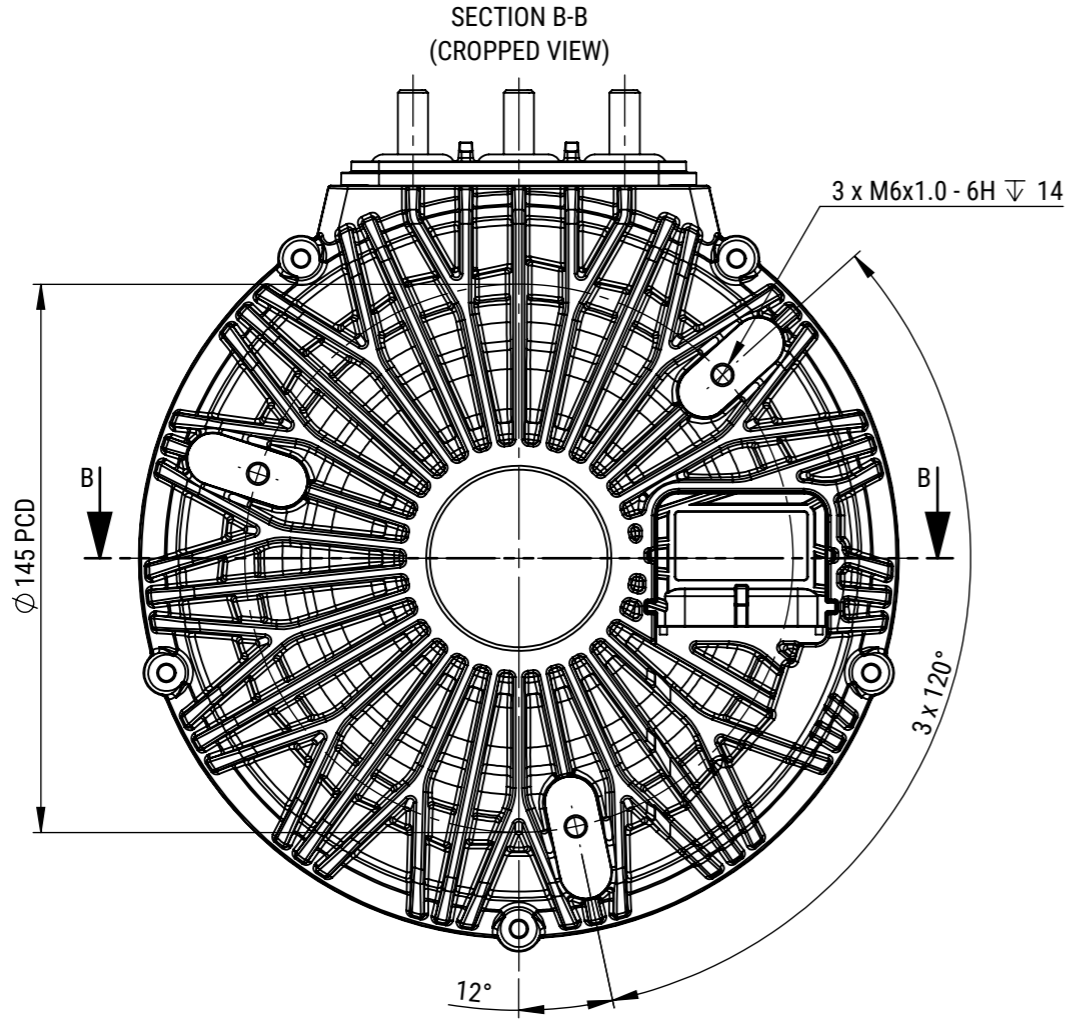
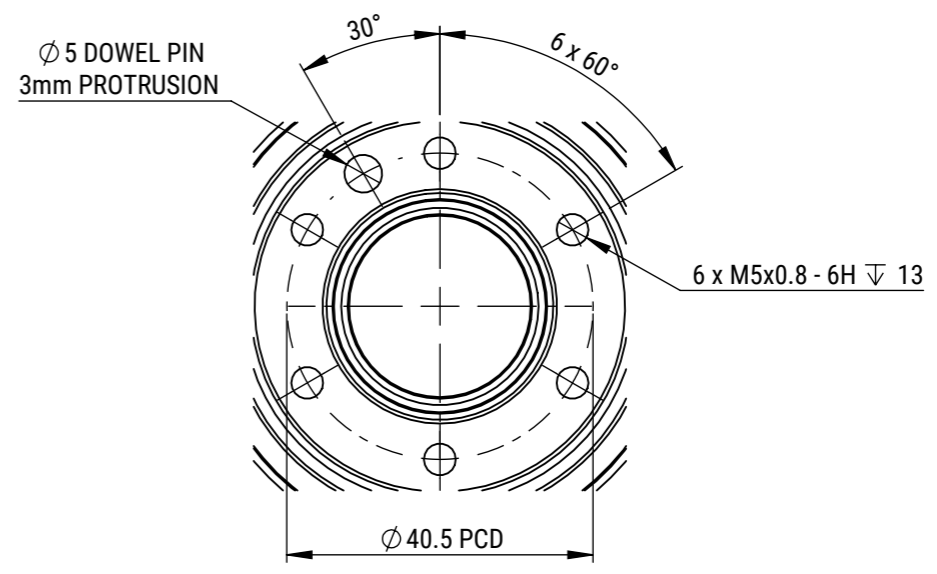
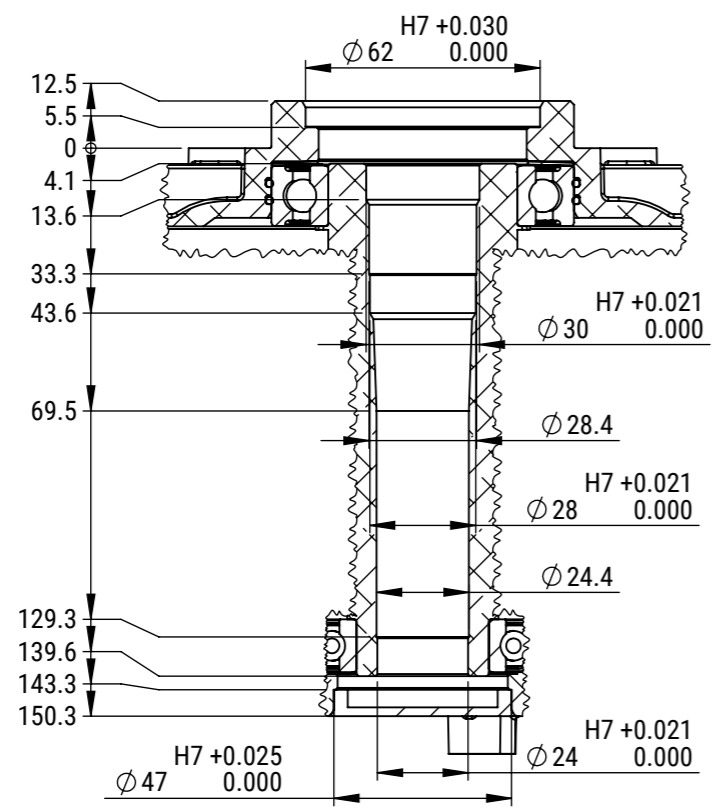

REV	CHANGE REF	DESCRIPTION	DRAWN BY	CHECKED	APPROVED	DATE
1	ECN069	PRODUCTION APPROVED	EB	SD	SD	28/05/2025

TITLE: **193-080-10A+, NO INTERFACE, 48V, IP6X**

DWG NO. **2019-002-080** REV **1** SCALE **1:2** MASS (APPROX.) **18.06kg**

electrified motors

ELECTRIFIED AUTOMATION LTD,
UNIT 4 BEECH BUSINESS PARK,
BRIDGWATER,
SOMERSET, TA6 4FF, UNITED KINGDOM

IF IN DOUBT - ASK ALL DIMENSION IN MM CONFORMS TO BS8888

©2025 ELECTRIFIED AUTOMATION LTD.
REPRODUCTION OR TRANSMISSION OF DATA HEREIN IS FORBIDDEN WITHOUT WRITTEN PERMISSION FROM ELECTRIFIED AUTOMATION LTD.

DOCUMENT TYPE: **ASSEMBLY DRAWING**

DOCUMENT STATUS: **PRODUCTION APPROVED**

STRICTLY NO DEVIATION FROM DRAWING PERMISSABLE WITHOUT APPROVED CONCESSION FROM ELECTRIFIED AUTOMATION

SHEET **2 OF 2** SHEET **A3**