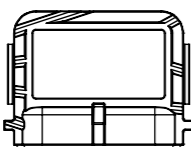

MOTOR TYPE	EA-193-80-13A+	
VOLTAGE	VDC	48
IEC DUTY	S2	60
RATED POWER	KW	8
RATED SPEED	RPM	2500
RATED FREQ.	HZ	208
IP RATING*	IP	6X
INSUL. CLASS	-	200
SENSOR CYCLES	CPR	5
TEMP SENSOR	PT1000	CLASS B

ENCODER:	SUPERSEAL 1.5 SOCKET
 PIN 1 : 5V PIN 2 : TEMP PIN 3 : SIN PIN 4 : COS PIN 5 : GND PIN 6 : SHIELD	MATING PLUG P/N: 282090-1 MATING PIN P/N: 183035-1

CUSTOMER APPROVAL:	NAME:
	DATE:
	SIGNED:

- NOTES:
- SHAFT ROTATES CW, WHEN VIEWED FROM DRIVE END, WHEN COSINE SIGNAL LEADS SINE SIGNAL BY 90 DEGREES
 - SHAFT ROTATES CW, WHEN VIEWED FROM DRIVE END, WHEN U-V-W WIRED PER DIAGRAM
 - TERMINAL NUTS: TORQUE TO 15Nm
 - SEE MANUAL FOR RECOMMENDED TORQUE VALUES OF MOTOR FASTENERS
 - ESTIMATED ROTATIONAL MOMENT OF INERTIA: 10971 kg/mm²
 - * IP RATINGS - SEE USER MANUAL FOR FURTHER DETAILS

REV	CHANGE REF	DESCRIPTION	DRAWN BY	CHECKED	APPROVED	DATE
1	ECN069	PRODUCTION RELEASE	EB	SD	SD	29/05/2025

TITLE: **193-080-13A+, NO INTERFACE, 48V, IP6X**

DWG NO. **2019-002-081** REV **1** SCALE **1:2**

electrified motors

ELECTRIFIED AUTOMATION LTD,
UNIT 4 BEECH BUSINESS PARK,
BRIDGWATER,
SOMERSET, TA6 4FF, UNITED KINGDOM

©2025 ELECTRIFIED AUTOMATION LTD.
REPRODUCTION OR TRANSMISSION OF DATA HEREIN IS
FORBIDDEN WITHOUT WRITTEN PERMISSION FROM
ELECTRIFIED AUTOMATION LTD.

STRICTLY NO DEVIATION FROM
DRAWING PERMISSABLE WITHOUT
APPROVED CONCESSION FROM
ELECTRIFIED AUTOMATION

IF IN DOUBT - ASK
ALL DIMENSION IN MM
CONFORMS TO BS8888

DOCUMENT TYPE	DOCUMENT STATUS	SHEET
ASSEMBLY DRAWING	PRODUCTION APPROVED	1 OF 2
		A3

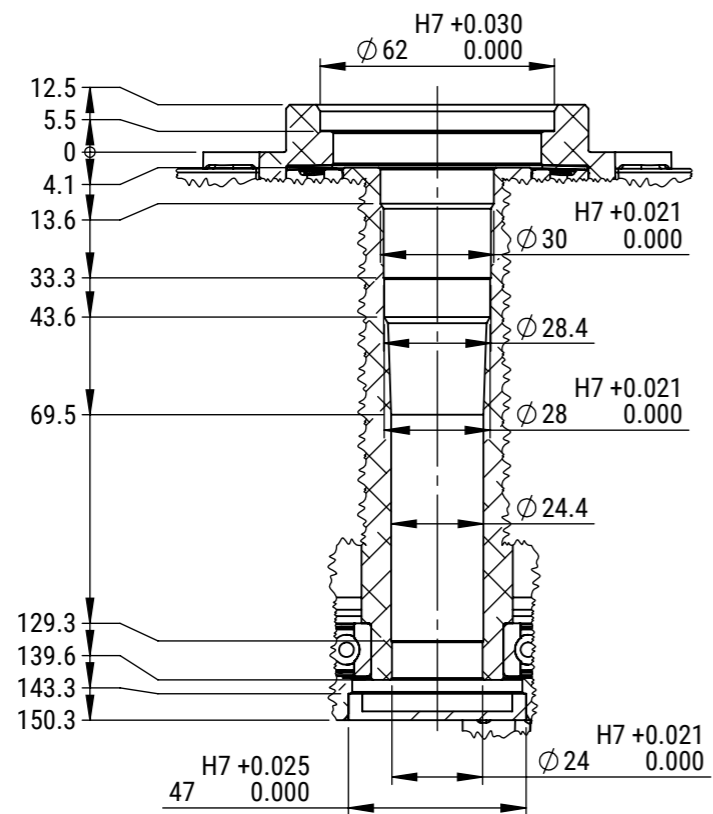

SECTION B-B
(CROPPED)

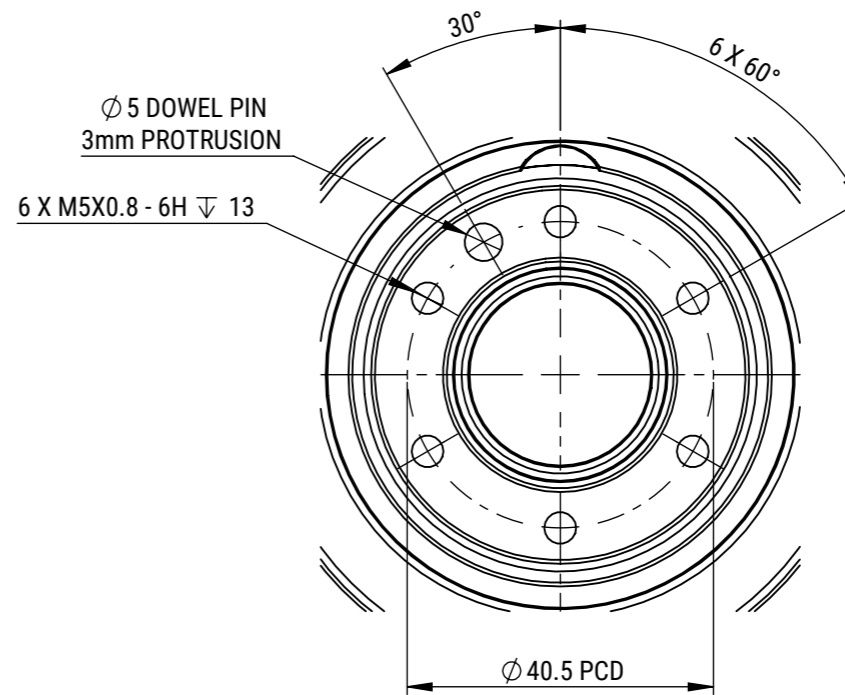

DETAIL A
SCALE 1 : 1

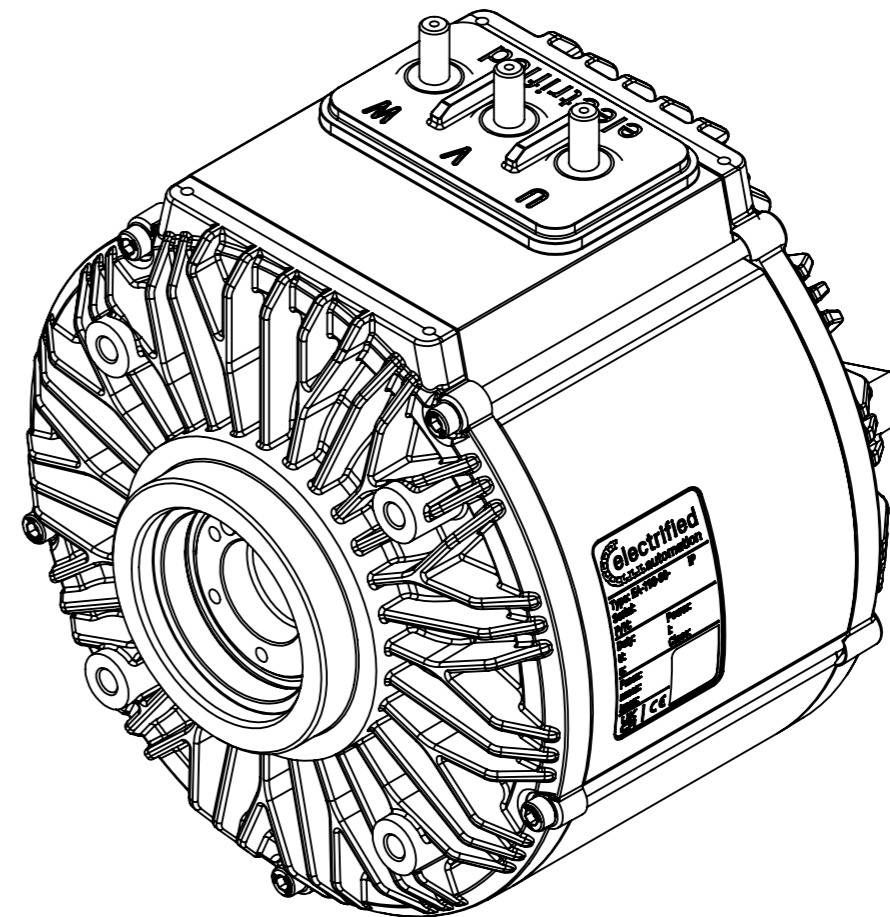
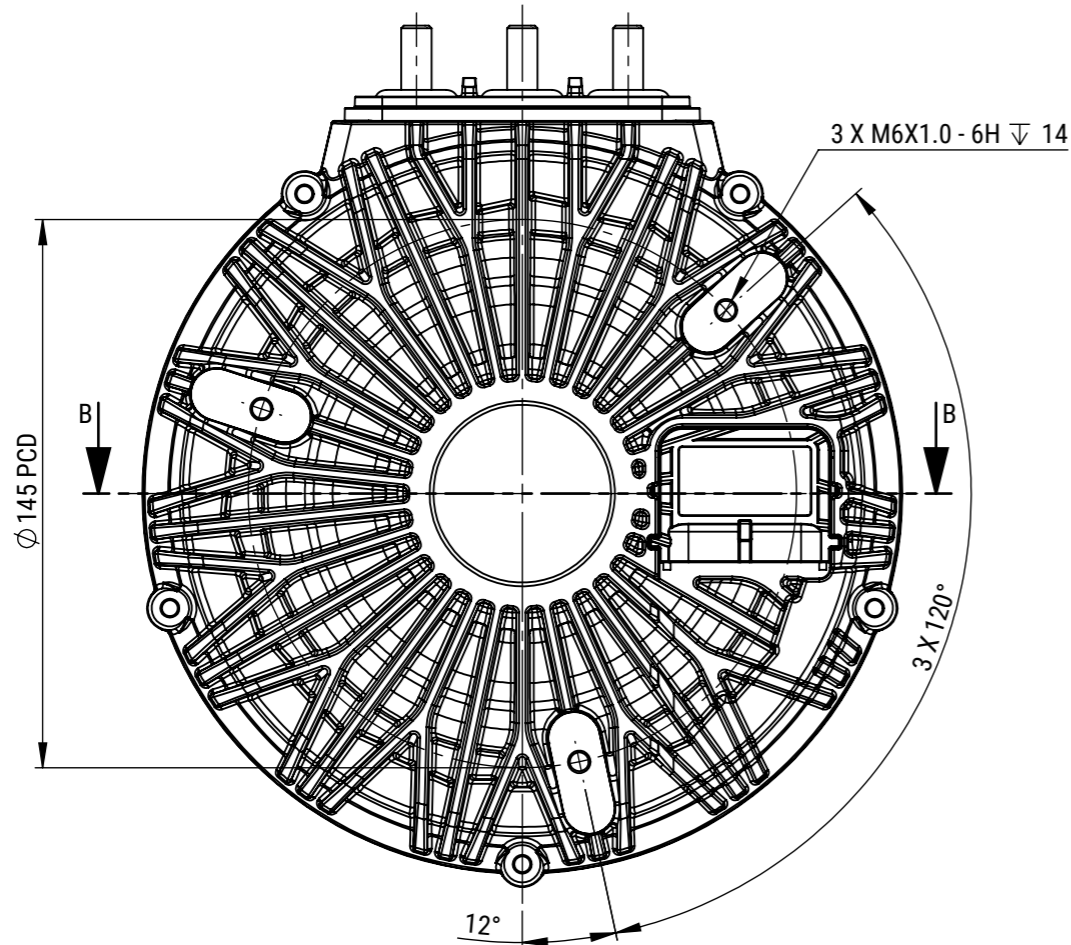

ISOMETRIC VIEW

REV	CHANGE REF	DESCRIPTION	DRAWN BY	CHECKED	APPROVED	DATE
1	ECN069	PRODUCTION RELEASE	EB	SD	SD	29/05/2025

TITLE: 193-080-13A+, NO INTERFACE, 48V, IP6X						
DWG NO.	REV	SCALE	MASS (APPROX.)			
2019-002-081	1	1:2	18.06kg			

electrified motors

ELECTRIFIED AUTOMATION LTD,
UNIT 4 BEECH BUSINESS PARK,
BRIDGWATER,
SOMERSET, TA6 4FF, UNITED KINGDOM

©2025 ELECTRIFIED AUTOMATION LTD.
REPRODUCTION OR TRANSMISSION OF DATA HEREIN IS
FORBIDDEN WITHOUT WRITTEN PERMISSION FROM
ELECTRIFIED AUTOMATION LTD.

STRICTLY NO DEVIATION FROM
DRAWING PERMISSABLE WITHOUT
APPROVED CONCEPTION FROM
ELECTRIFIED AUTOMATION

IF IN DOUBT - ASK
ALL DIMENSION IN MM
CONFORMS TO BS8888

DOCUMENT TYPE	DOCUMENT STATUS	SHEET
ASSEMBLY DRAWING	PRODUCTION APPROVED	2 OF 2

A3