

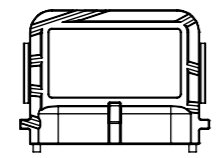

MOTOR TYPE	EA-193-80-10A+		ENCODER:	SUPERSEAL 1.5 SOCKET	CUSTOMER APPROVAL:
VOLTAGE	VDC	48	 PIN 1: 5V PIN 2: TEMP PIN 3: SIN PIN 4: COS PIN 5: GND PIN 6: SHIELD	MATING PLUG P/N:	NAME:
IEC DUTY	S2	60		282090-1	DATE:
RATED POWER	KW	10		MATING PIN P/N:	SIGNED:
RATED SPEED	RPM	4000		183035-1	
RATED FREQ.	HZ	333			
IP RATING*	IP	65			
INSUL. CLASS	-	200			
SENSOR CYCLES	CPR	5			
TEMP SENSOR	PT1000	CLASS B			

- NOTES:
- SHAFT ROTATES CW, WHEN VIEWED FROM DRIVE END, WHEN COSINE SIGNAL LEADS SINE SIGNAL BY 90 DEGREES
  - SHAFT ROTATES CW, WHEN VIEWED FROM DRIVE END, WHEN U-V-W WIRED PER DIAGRAM
  - TERMINAL NUTS: TORQUE TO 15Nm
  - SEE MANUAL FOR RECOMMENDED TORQUE VALUES OF MOTOR FASTENERS
  - ESTIMATED ROTATIONAL MOMENT OF INERTIA: 11031 kg/mm<sup>2</sup>
  - \* IP RATINGS - SEE USER MANUAL FOR FURTHER DETAILS

REV	CHANGE REF	DESCRIPTION	DRAWN BY	CHECKED	APPROVED	DATE	TITLE:	 ELECTRIFIED AUTOMATION LTD, UNIT 4 BEECH BUSINESS PARK, BRIDGWATER, SOMERSET, TA6 4FF, UNITED KINGDOM	©2025 ELECTRIFIED AUTOMATION LTD. REPRODUCTION OR TRANSMISSION OF DATA HEREIN IS FORBIDDEN WITHOUT WRITTEN PERMISSION FROM ELECTRIFIED AUTOMATION LTD.	STRICTLY NO DEVIATION FROM DRAWING PERMISSABLE WITHOUT APPROVED CONCESSION FROM ELECTRIFIED AUTOMATION				
1	ECN069	PRODUCTION APPROVED	EB	SD	SD	29/05/2025	193-080-10A+, SAE A, Z9, 48V, IP65							
							DWG NO.	REV	SCALE	MASS (APPROX.)	 IF IN DOUBT - ASK ALL DIMENSION IN MM CONFORMS TO BS8888	DOCUMENT TYPE	DOCUMENT STATUS	SHEET
							2019-002-083	1	1:2	19.37kg		ASSEMBLY DRAWING	PRODUCTION APPROVED	1 OF 2

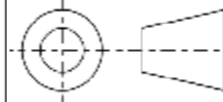
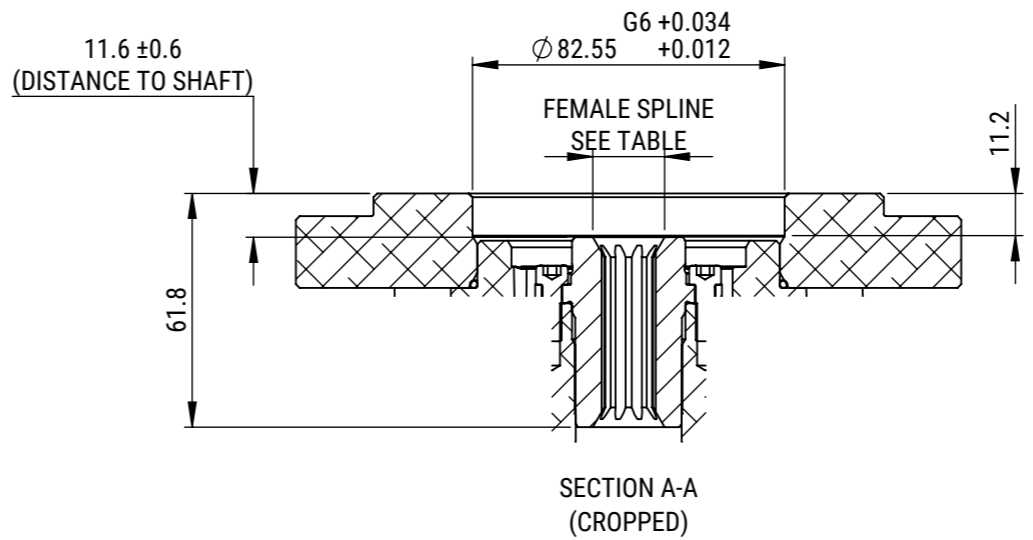
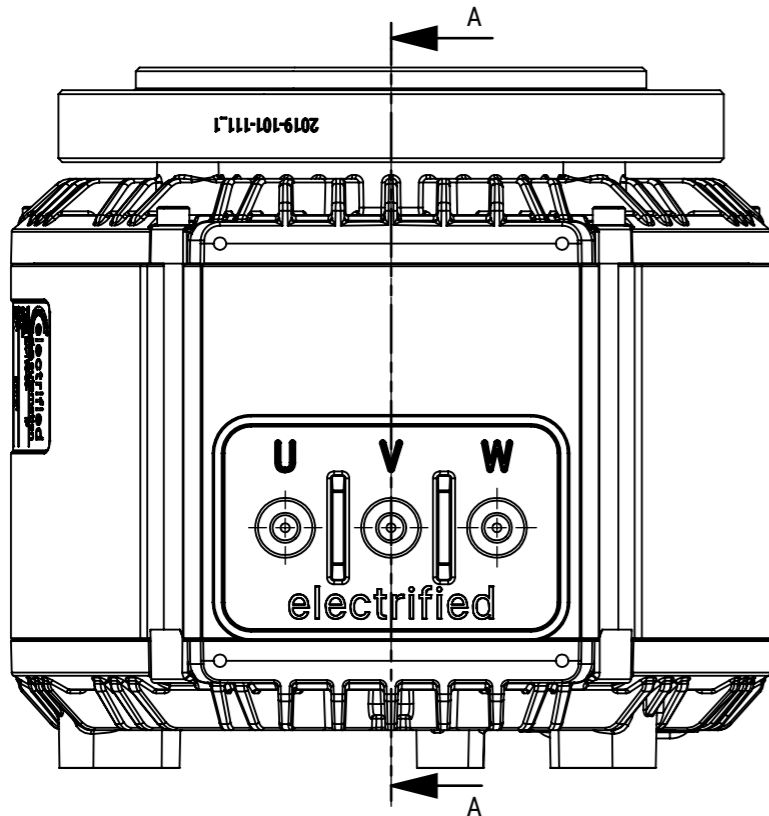

INTERNAL INVOLUTE SPLINE DATA		
SPEC.	ANSI B92.1 1996	
SPLINE TYPE	FLAT ROOT / SIDE FIT	
CLASS		5
NUMBER OF TEETH		9
SPLINE PITCH		16/32
PRESSURE ANGLE	°	30
BASE DIAMETER (REF)	MM	12.373
PITCH DIMETER (REF)	MM	14.288
MAJOR DIAMETER (MAX)	MM	16.535
FORM DIAMETER	MM	15.977
MINOR DIAMETER	MM	13.056
		12.929
MIN. EFF. CIRC. SPACE WIDTH (Sv)	MM	2.494
MAX. ACTUAL SPACE WIDTH (Sv)		2.560
MEASUREMENT BETWEEN PINS	MM	10.089
		10.041
PIN DIAMETER	MM	2.743

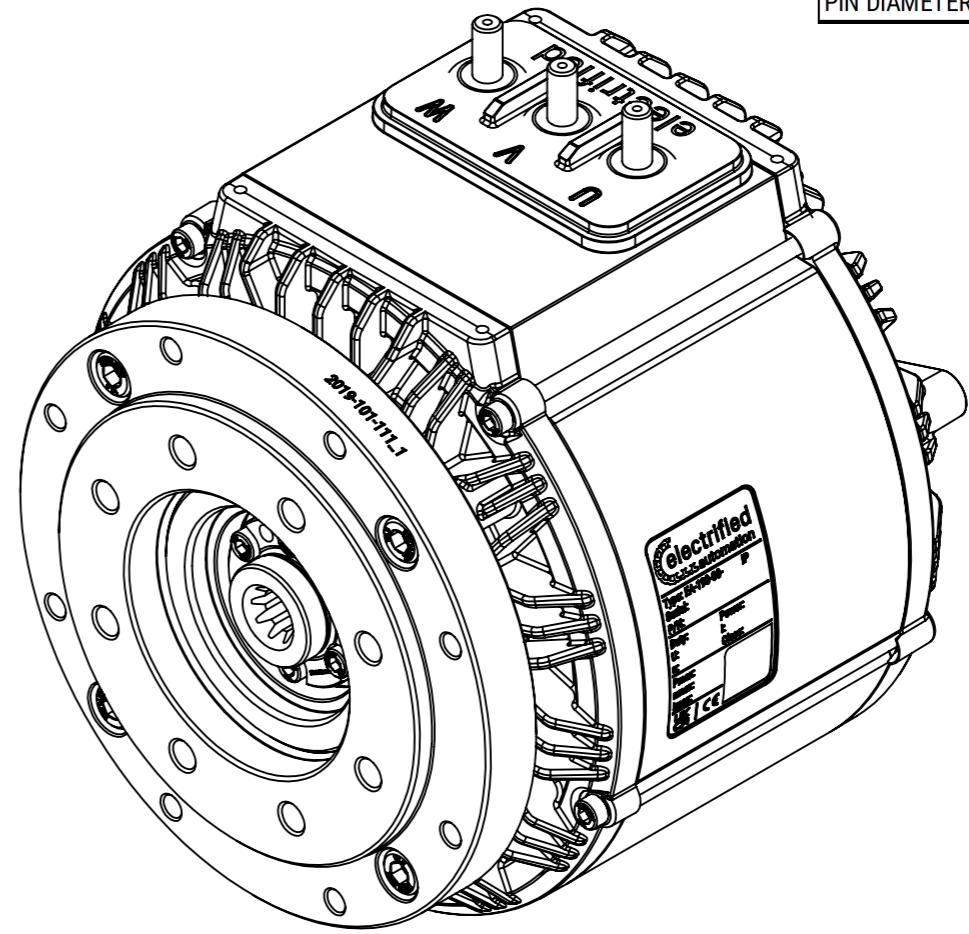
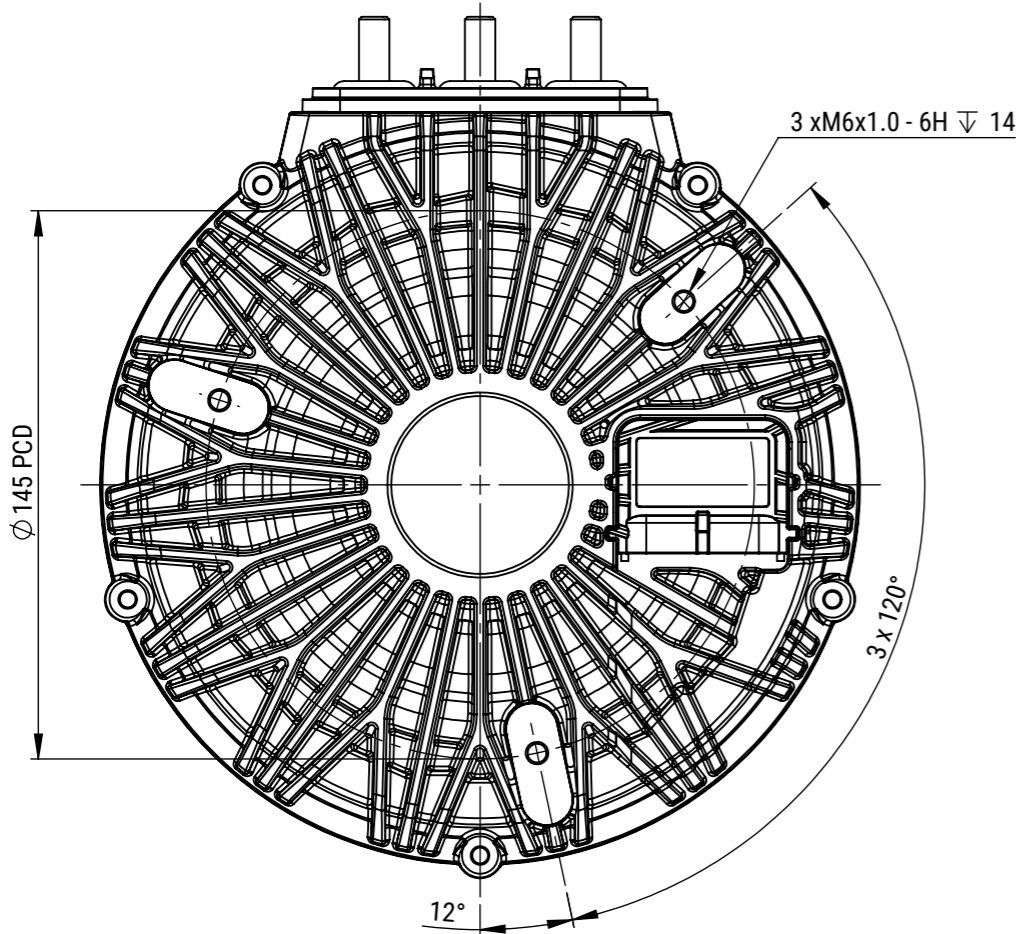

ISOMETRIC VIEW

REV	CHANGE REF	DESCRIPTION	DRAWN BY	CHECKED	APPROVED	DATE
1	ECN069	PRODUCTION APPROVED	EB	SD	SD	29/05/2025

TITLE: **193-080-10A+, SAE A, Z9, 48V, IP65**

DWG NO. **2019-002-083**

REV **1**

SCALE **1:2**

MASS (APPROX.) **19.37kg**

ELECTRIFIED AUTOMATION LTD,  
UNIT 4 BEECH BUSINESS PARK,  
BRIDGWATER,  
SOMERSET, TA6 4FF, UNITED KINGDOM

IF IN DOUBT - ASK ALL DIMENSION IN MM CONFORMS TO BS8888

©2025 ELECTRIFIED AUTOMATION LTD. REPRODUCTION OR TRANSMISSION OF DATA HEREIN IS FORBIDDEN WITHOUT WRITTEN PERMISSION FROM ELECTRIFIED AUTOMATION LTD.

STRICTLY NO DEVIATION FROM DRAWING PERMISSABLE WITHOUT APPROVED CONCESSION FROM ELECTRIFIED AUTOMATION

DOCUMENT TYPE: **ASSEMBLY DRAWING**

DOCUMENT STATUS: **PRODUCTION APPROVED**

SHEET: **2 OF 2**

**A3**