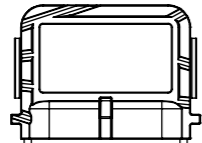

MOTOR TYPE	EA-193-40-18A+		ENCODER:	SUPERSEAL 1.5 SOCKET	CUSTOMER APPROVAL:
VOLTAGE	VDC	48	 PIN 1 : 5V PIN 2 : TEMP PIN 3 : SIN PIN 4 : COS PIN 5 : GND PIN 6 : SHIELD	MATING PLUG P/N:	NAME:
IEC DUTY	S2	60		282090-1	DATE:
RATED POWER	KW	5.5		MATING PIN P/N:	SIGNED:
RATED SPEED	RPM	4000		183035-1	
RATED FREQ.	HZ	333			
IP RATING*	IP	65			
INSUL. CLASS	-	200			
SENSOR CYCLES	CPR	5			
TEMP SENSOR	PT1000	CLASS B			

NOTES:

- KEYWAY DIMENSIONS TO ISO/R773
- SHAFT ROTATES CW, WHEN VIEWED FROM DRIVE END, WHEN COSINE SIGNAL LEADS SINE SIGNAL BY 90 DEGREES
- SHAFT ROTATES CW, WHEN VIEWED FROM DRIVE END, WHEN U-V-W WIRED PER DIAGRAM
- TERMINAL NUTS: TORQUE TO 15Nm
- SEE MANUAL FOR RECOMMENDED TORQUE VALUES OF MOTOR FASTENERS
- ESTIMATED ROTATIONAL MOMENT OF INERTIA: 5704 kg/mm²
- * IP RATINGS - SEE USER MANUAL FOR FURTHER DETAILS

REV	CHANGE REF	DESCRIPTION	DRAWN BY	CHECKED	APPROVED	DATE
1	ECN069	PRODUCTION APPROVED	EB	SD	SD	18/06/2025

TITLE: **193-040-18A+, STD, 24MM KEYED, 48V, IP65**

DWG NO. **2019-002-086** REV **1** SCALE **1:2**

electrified motors

MASS (APPROX.) **11.30kg**

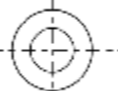

ELECTRIFIED AUTOMATION LTD,
UNIT 4 BEECH BUSINESS PARK,
BRIDGWATER,
SOMERSET, TA6 4FF, UNITED KINGDOM

IF IN DOUBT - ASK ALL DIMENSION IN MM CONFORMS TO BS8888

©2025 ELECTRIFIED AUTOMATION LTD.
REPRODUCTION OR TRANSMISSION OF DATA HEREIN IS FORBIDDEN WITHOUT WRITTEN PERMISSION FROM ELECTRIFIED AUTOMATION LTD.

DOCUMENT TYPE **ASSEMBLY DRAWING**

STRICTLY NO DEVIATION FROM DRAWING PERMISSABLE WITHOUT APPROVED CONCESSION FROM ELECTRIFIED AUTOMATION

DOCUMENT STATUS **PRODUCTION APPROVED**

SHEET **1 OF 2**

A3

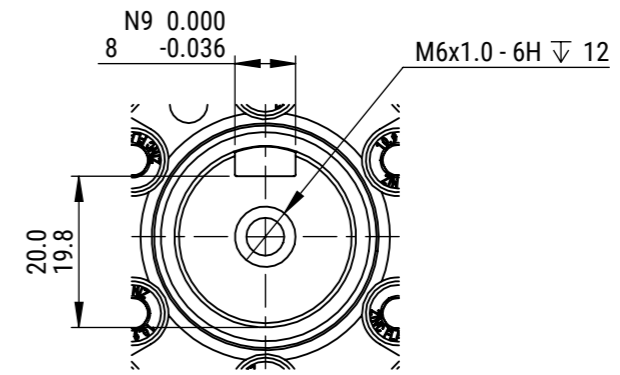
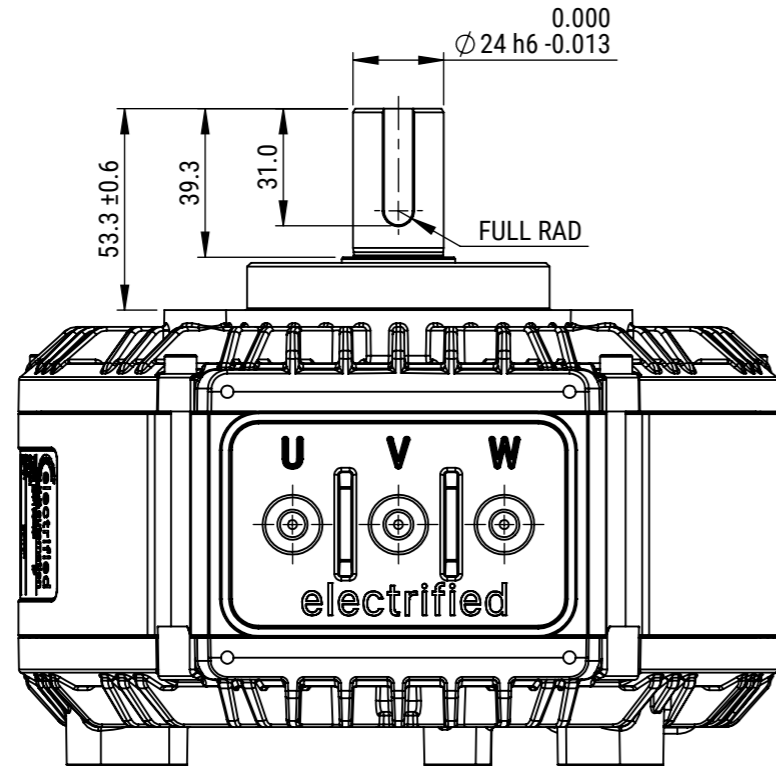

DETAIL A
SCALE 1:1

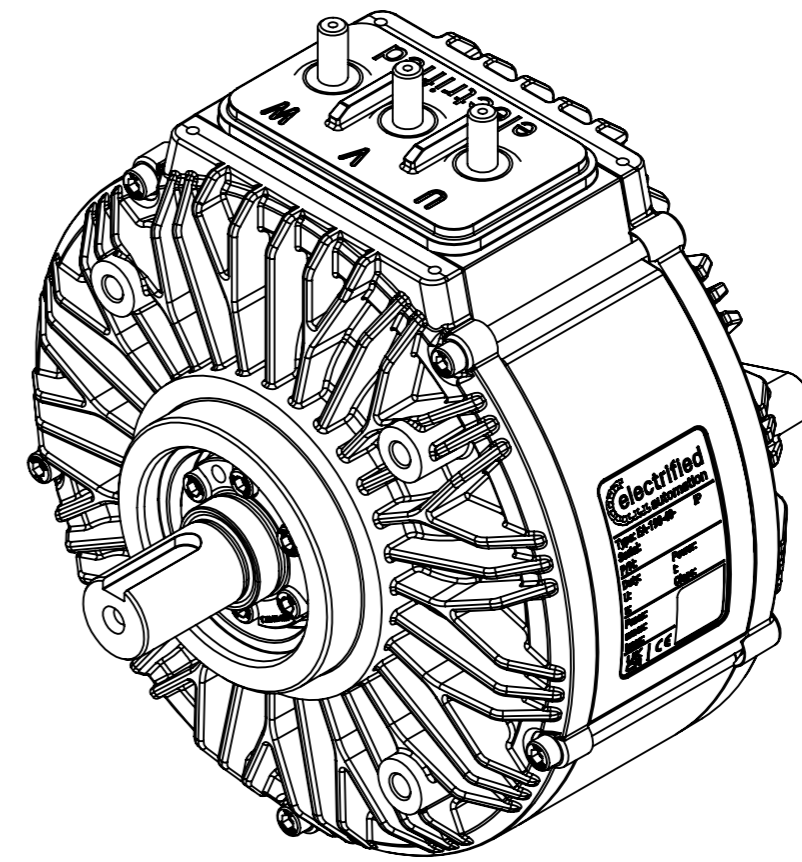
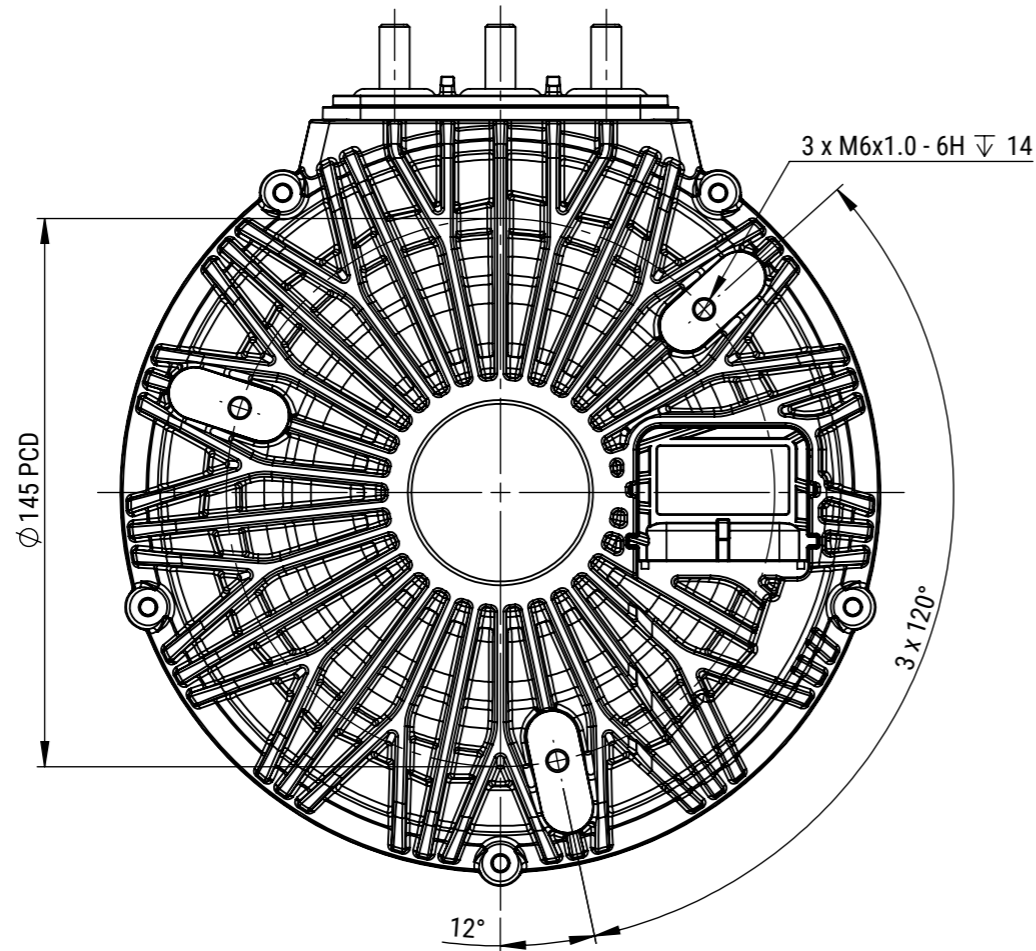

ISOMETRIC VIEW

REV	CHANGE REF	DESCRIPTION	DRAWN BY	CHECKED	APPROVED	DATE
1	ECN069	PRODUCTION APPROVED	EB	SD	SD	18/06/2025

TITLE: **193-040-18A+, STD,
24MM KEYED, 48V, IP65**



ELECTRIFIED AUTOMATION LTD,
UNIT 4 BEECH BUSINESS PARK,
BRIDGWATER,
SOMERSET, TA6 4FF, UNITED KINGDOM

©2025 ELECTRIFIED AUTOMATION LTD.
REPRODUCTION OR TRANSMISSION OF DATA HEREIN IS
FORBIDDEN WITHOUT WRITTEN PERMISSION FROM
ELECTRIFIED AUTOMATION LTD.

STRICTLY NO DEVIATION FROM
DRAWING PERMISSABLE WITHOUT
APPROVED CONCESSION FROM
ELECTRIFIED AUTOMATION

DWG NO. **2019-002-086**

REV **1**

SCALE **1:2**

MASS (APPROX.) **11.30kg**

IF IN DOUBT - ASK
ALL DIMENSION IN MM
CONFORMS TO BS8888

DOCUMENT TYPE
**ASSEMBLY
DRAWING**

DOCUMENT STATUS
**PRODUCTION
APPROVED**

SHEET
2 OF 2

A3