

MOTOR TYPE	EA-193-40-18A+	
VOLTAGE	VDC	48
IEC DUTY	S2	60
RATED POWER	KW	5.5
RATED SPEED	RPM	4000
MAX. SPEED	RPM	8000
MAX. FREQ.	HZ	667
IP RATING*	IP	65
INSUL. CLASS	-	200
SENSOR CYCLES	CPR	5
TEMP SENSOR	PT1000	CLASS B

**ENCODER:**

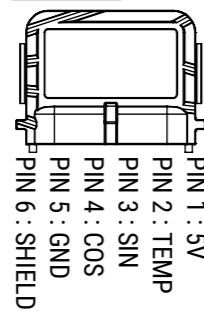

**SUPERSEAL 1.5 SOCKET**

MATING PLUG P/N:  
282090-1  
  
MATING PIN P/N:  
183035-1

**CUSTOMER APPROVAL:**

NAME:  
DATE:  
SIGNED:

**NOTES:**

- SHAFT ROTATES CW, WHEN VIEWED FROM DRIVE END, WHEN COSINE SIGNAL LEADS SINE SIGNAL BY 90 DEGREES
- SHAFT ROTATES CW, WHEN VIEWED FROM DRIVE END, WHEN U-V-W WIRED PER DIAGRAM
- TERMINAL NUTS: TORQUE TO 15Nm
- SEE MANUAL FOR RECOMMENDED TORQUE VALUES OF MOTOR FASTENERS
- ESTIMATED ROTATIONAL MOMENT OF INERTIA: 5731 kg/mm<sup>2</sup>
- \* IP RATINGS - SEE USER MANUAL FOR DETAILS

REV	CHANGE REF	DESCRIPTION	DRAWN BY	CHECKED	APPROVED	DATE
1	ECN069	PRODUCTION APPROVED	EB	SD	SD	03/04/2025

**TITLE:**  
193-040-18A+,  
B5/100, 48V, IP65



ELECTRIFIED AUTOMATION LTD,  
UNIT 4 BEECH BUSINESS PARK,  
BRIDGWATER,  
SOMERSET, TA6 4FF, UNITED KINGDOM

©2025 ELECTRIFIED AUTOMATION LTD.  
REPRODUCTION OR TRANSMISSION OF DATA HEREIN IS  
FORBIDDEN WITHOUT WRITTEN PERMISSION FROM  
ELECTRIFIED AUTOMATION LTD.

STRICTLY NO DEVIATION FROM  
DRAWING PERMISSABLE WITHOUT  
APPROVED CONCESSION FROM  
ELECTRIFIED AUTOMATION

DWG NO.	REV	SCALE	MASS
2019-002-112	1	1:2	12.82kg

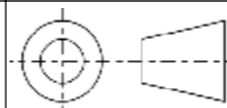

IF IN DOUBT - ASK  
ALL DIMENSION IN MM  
CONFORMS TO BS8888

DOCUMENT TYPE  
**ASSEMBLY  
DRAWING**

DOCUMENT STATUS  
**PRODUCTION  
APPROVED**

SHEET  
1 OF 2

**A3**

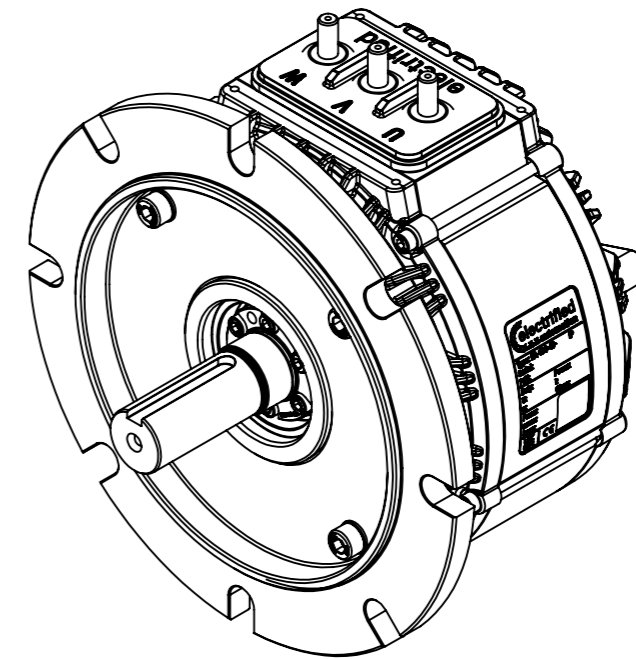
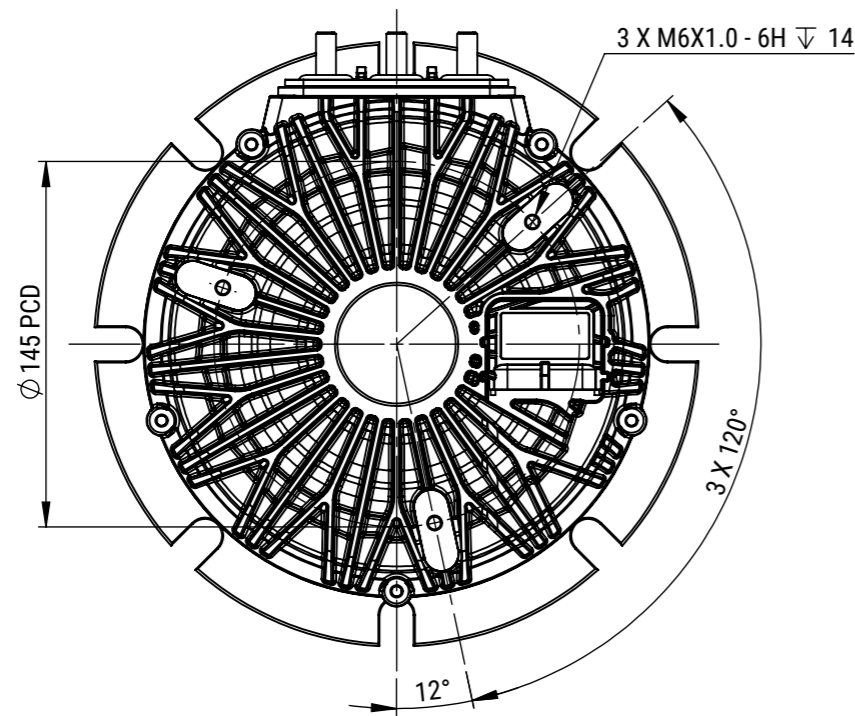
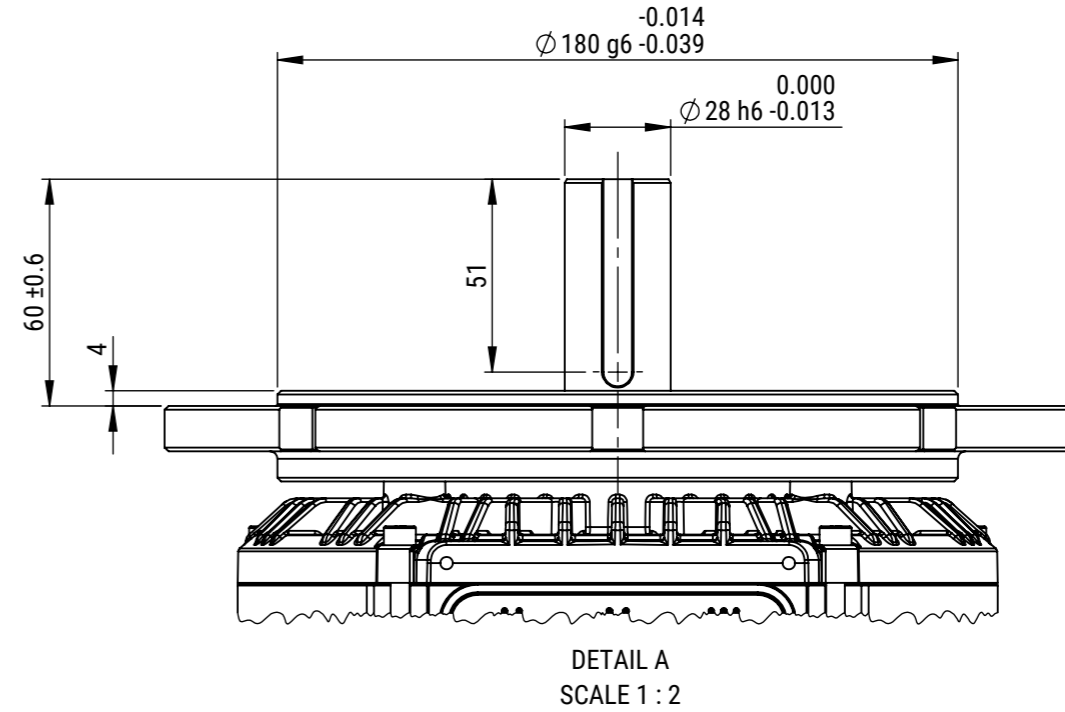
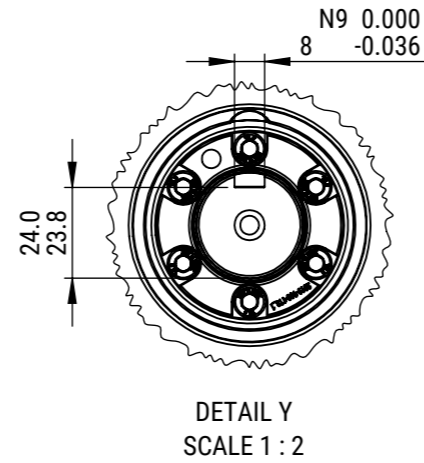
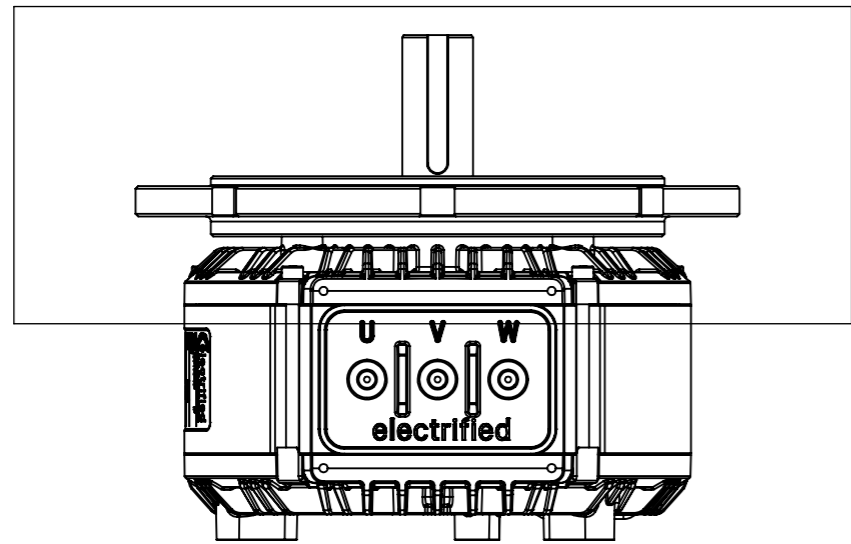

ISOMETRIC VIEW

REV	CHANGE REF	DESCRIPTION	DRAWN BY	CHECKED	APPROVED	DATE
1	ECN069	PRODUCTION APPROVED	EB	SD	SD	03/04/2025

TITLE: **193-040-18A+,  
B5/100, 48V, IP65**



ELECTRIFIED AUTOMATION LTD,  
UNIT 4 BEECH BUSINESS PARK,  
BRIDGWATER,  
SOMERSET, TA6 4FF, UNITED KINGDOM

©2025 ELECTRIFIED AUTOMATION LTD.  
REPRODUCTION OR TRANSMISSION OF DATA HEREIN IS  
FORBIDDEN WITHOUT WRITTEN PERMISSION FROM  
ELECTRIFIED AUTOMATION LTD.

STRICTLY NO DEVIATION FROM  
DRAWING PERMISSABLE WITHOUT  
APPROVED CONCESSION FROM  
ELECTRIFIED AUTOMATION

DWG NO. <b>2019-002-112</b>	REV <b>1</b>	SCALE <b>1:3</b>	MASS <b>12.82kg</b>	IF IN DOUBT - ASK ALL DIMENSION IN MM CONFORMS TO BS8888	DOCUMENT TYPE <b>ASSEMBLY DRAWING</b>	DOCUMENT STATUS <b>PRODUCTION APPROVED</b>	SHEET <b>2 OF 2</b>	<b>A3</b>
--------------------------------	-----------------	---------------------	------------------------	--	--	---	------------------------	-----------