

MOTOR TYPE	EA-193-80-13A+		ENCODER:	SUPERSEAL 1.5 SOCKET	CUSTOMER APPROVAL:
VOLTAGE	VDC	48		MATING PLUG P/N:	NAME:
IEC DUTY	S2	60		MATING PLUG P/N:	DATE:
RATED POWER	KW	8		MATING PIN P/N:	SIGNED:
RATED SPEED	RPM	2500		183035-1	
RATED FREQ.	HZ	208			
IP RATING*	IP	65			
INSUL. CLASS	-	200			
SENSOR CYCLES	CPR	5			
TEMP SENSOR	PT1000	CLASS B			

- NOTES:
- KEYWAY DIMENSIONS TO ISO/R773
 - SHAFT ROTATES CW, WHEN VIEWED FROM DRIVE END, WHEN COSINE SIGNAL LEADS SINE SIGNAL BY 90 DEGREES
 - SHAFT ROTATES CW, WHEN VIEWED FROM DRIVE END, WHEN U-V-W WIRED PER DIAGRAM
 - TERMINAL NUTS: TORQUE TO 15Nm
 - SEE MANUAL FOR RECOMMENDED TORQUE VALUES OF MOTOR FASTENERS
 - ESTIMATED ROTATIONAL MOMENT OF INERTIA: 11043 kg/mm²
 - * IP RATINGS - SEE USER MANUAL FOR FURTHER DETAILS

REV	CHANGE REF	DESCRIPTION	DRAWN BY	CHECKED	APPROVED	DATE
1	ECN069	PRODUCTION APPROVED	EB	SD	SD	25/04/2025

TITLE: **193-080-13A+, B5/100, 48V, IP65**

DWG NO. **2019-002-122** REV **1** SCALE **1:2**

electrified motors

ELECTRIFIED AUTOMATION LTD,
UNIT 4 BEECH BUSINESS PARK,
BRIDGWATER,
SOMERSET, TA6 4FF, UNITED KINGDOM

©2025 ELECTRIFIED AUTOMATION LTD.
REPRODUCTION OR TRANSMISSION OF DATA HEREIN IS
FORBIDDEN WITHOUT WRITTEN PERMISSION FROM
ELECTRIFIED AUTOMATION LTD.

STRICTLY NO DEVIATION FROM
DRAWING PERMISSABLE WITHOUT
APPROVED CONCESSION FROM
ELECTRIFIED AUTOMATION

IF IN DOUBT - ASK
ALL DIMENSION IN MM
CONFORMS TO BS8888

DOCUMENT TYPE	DOCUMENT STATUS	SHEET
ASSEMBLY DRAWING	PRODUCTION APPROVED	1 OF 2

A3

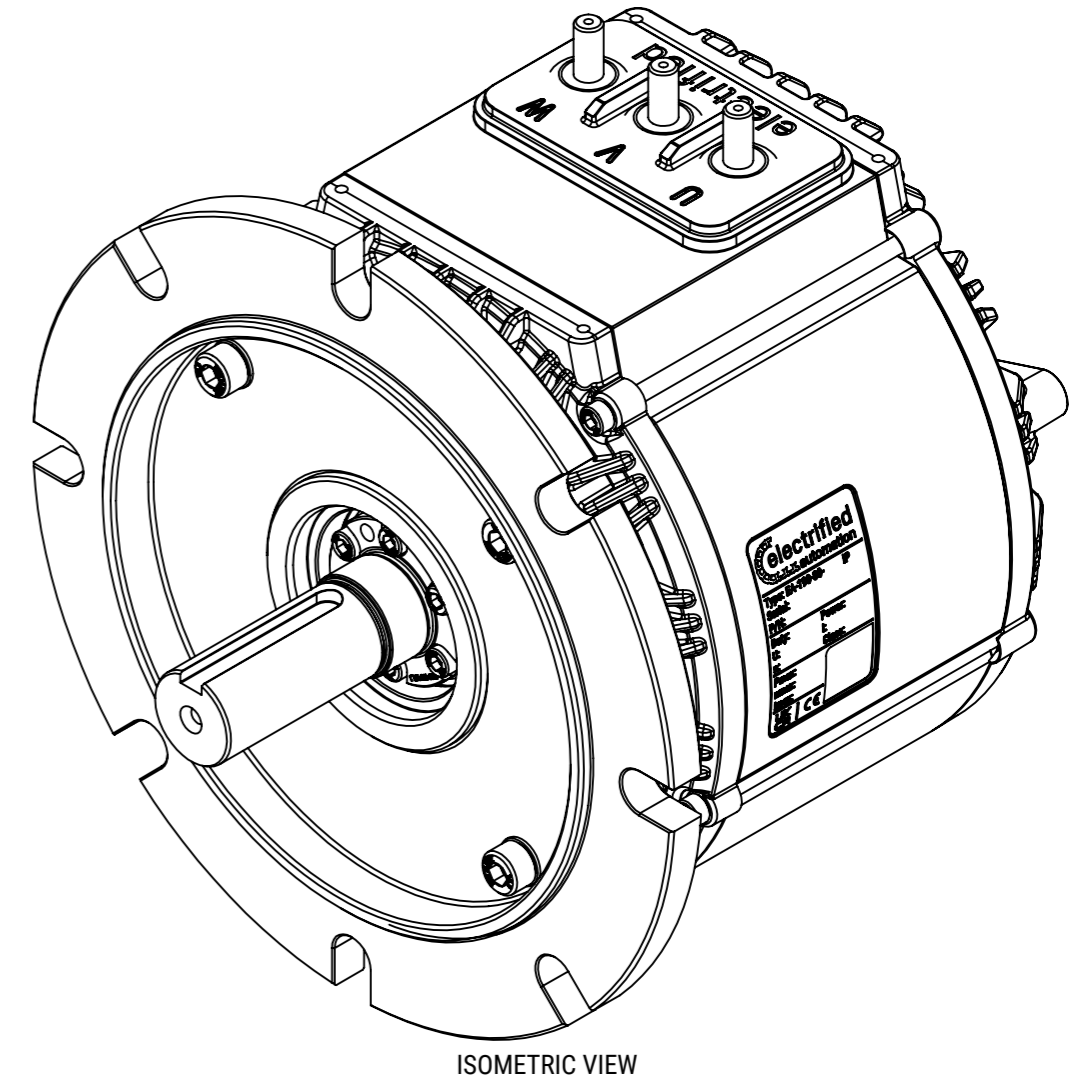
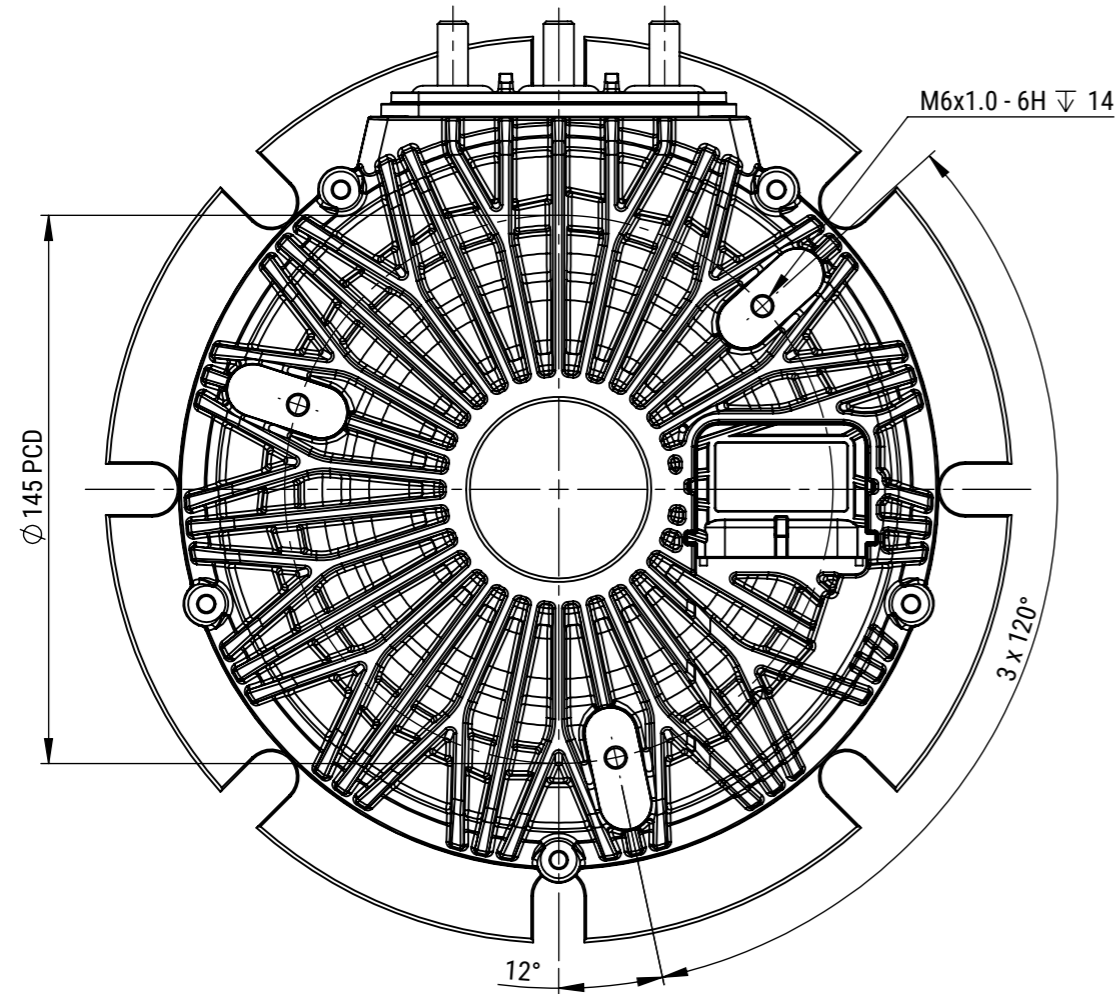
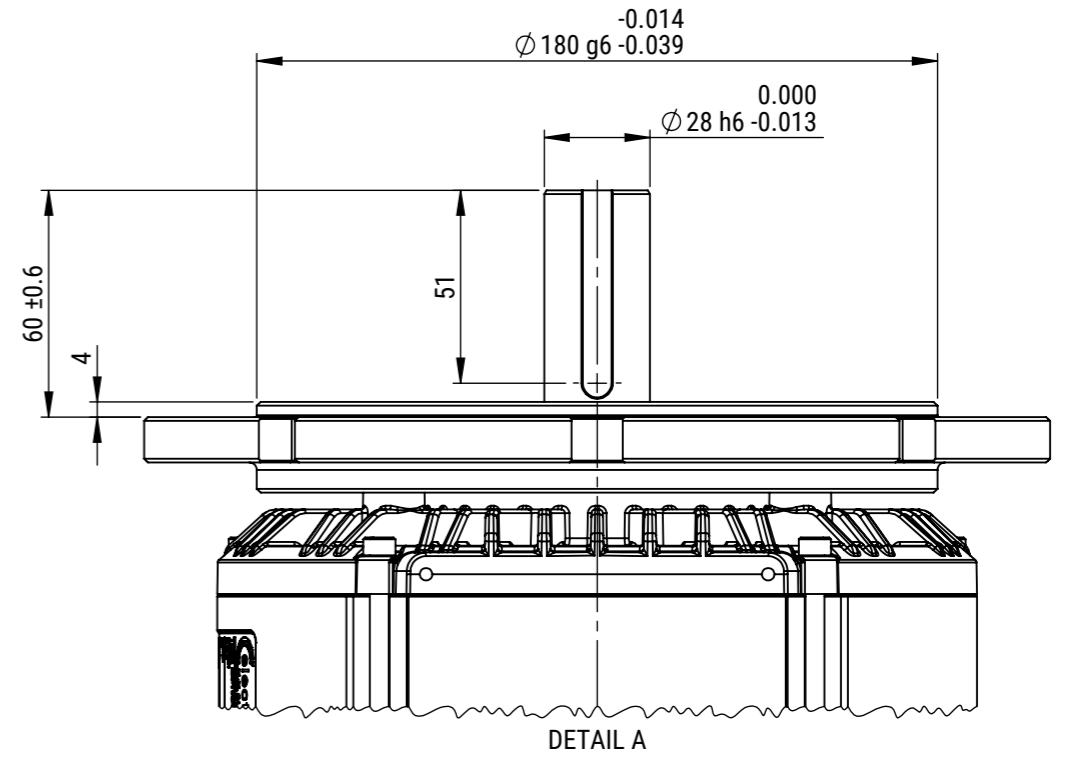
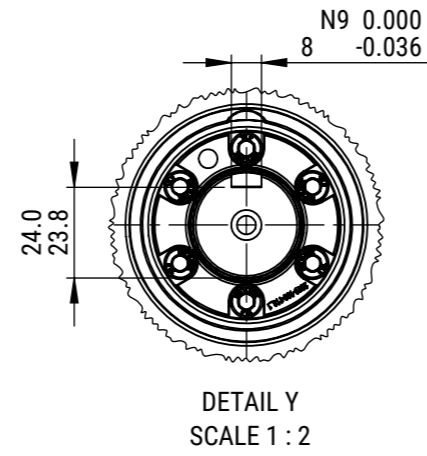
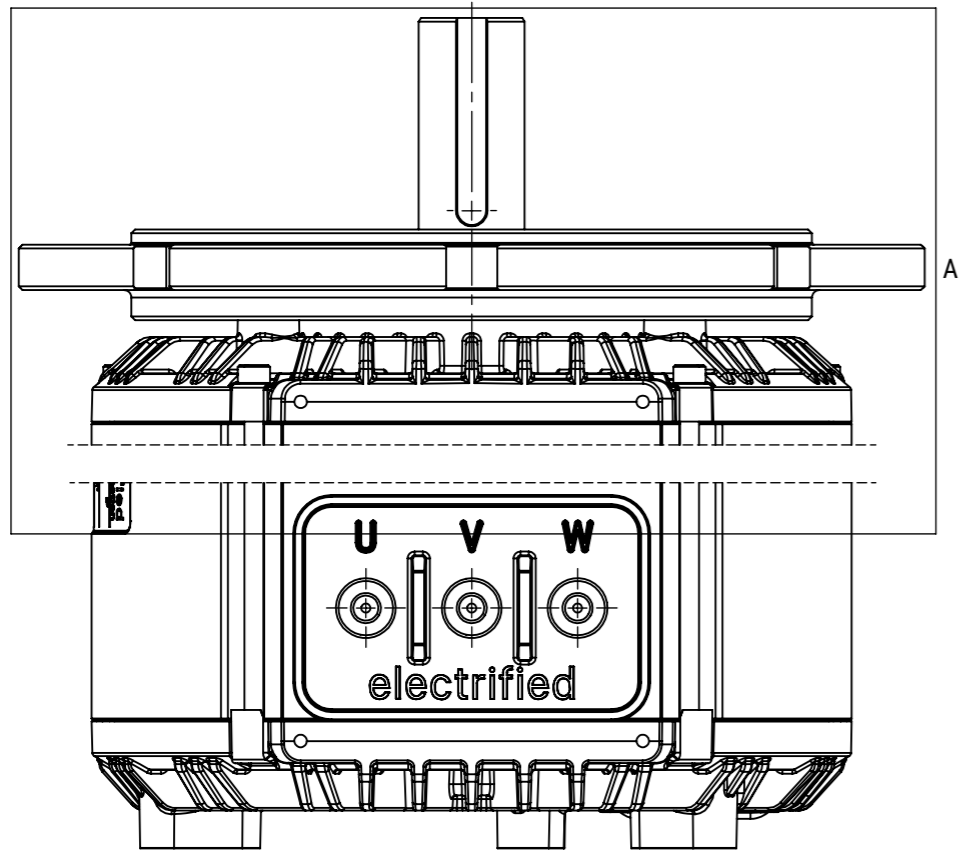

REV	CHANGE REF	DESCRIPTION	DRAWN BY	CHECKED	APPROVED	DATE
1	ECN069	PRODUCTION APPROVED	EB	SD	SD	25/04/2025

TITLE: 193-080-13A+, B5/100, 48V, IP65						
DWG NO.	REV	SCALE	MASS (APPROX.)			
2019-002-122	1	1:2	19.92kg			

ELECTRIFIED AUTOMATION LTD,
UNIT 4 BEECH BUSINESS PARK,
BRIDGWATER,
SOMERSET, TA6 4FF, UNITED KINGDOM

©2025 ELECTRIFIED AUTOMATION LTD.
REPRODUCTION OR TRANSMISSION OF DATA HEREIN IS
FORBIDDEN WITHOUT WRITTEN PERMISSION FROM
ELECTRIFIED AUTOMATION LTD.

STRICTLY NO DEVIATION FROM
DRAWING PERMISSABLE WITHOUT
APPROVED CONCEPTION FROM
ELECTRIFIED AUTOMATION

IF IN DOUBT - ASK ALL DIMENSION IN MM CONFORMS TO BS8888	DOCUMENT TYPE ASSEMBLY DRAWING	DOCUMENT STATUS PRODUCTION APPROVED	SHEET 2 OF 2	A3
--	--	---	-----------------	-----------