

CHARX T2HBI24-DC375-2,0C2 - Vehicle charging inlet



1720109

<https://www.phoenixcontact.com/gb/products/1720109>

Please be informed that the data shown in this PDF document is generated from our online catalog. Please find the complete data in the user documentation. Our general terms of use for downloads are valid.



The figure shows a version of the product

CHARX connect universal, DC CCS Typ 2, Vehicle charging inlet, > 500 A in Boost mode, 325 A permanent, 1000 V DC, Single wires, length: 2 m, locking actuator: 24 V, 4-pos., Front and rear mounting, M6, housing: black, for charging with direct current (DC), IEC 62196-1, IEC 62196-2, A protective cap is supplied as standard for the DC contacts.

Product description

Vehicle charging inlet for charging with direct current (DC), compatible with type 2 CCS vehicle charging connectors (EVSE), for installation in electric vehicles (EV).

Your advantages

- HPC-capable: a cable cross-section of 120 mm² enables permanent charging at 375 kW
- Waterproof, dirtproof, and dustproof due to IP6K6K/IP6K9K degree of protection in the front area – even with the charging flap open
- Easy design-in through the compact design, uniform dimensions, and identical screw-on points
- Developed and produced in accordance with the IATF 16949 automotive standard and ISO 9001

Commercial data

Item number	1720109
Packing unit	1 pc
Minimum order quantity	1 pc
Sales key	XWCAID
Product key	XWCAID
GTIN	4067923271364
Weight per piece (including packing)	8,030 g
Weight per piece (excluding packing)	8,030 g
Customs tariff number	85444290
Country of origin	PL

CHARX T2HBI24-DC375-2,0C2 - Vehicle charging inlet



1720109

<https://www.phoenixcontact.com/gb/products/1720109>

Technical data

Notes

General	A protective cap is supplied as standard for the DC contacts.
---------	---

Product properties

Product type	Vehicle charging inlet
Product family	CHARX connect universal
Charging standard	DC CCS Typ 2
Charging mode	Mode 4
Customer variations	On request

Electrical properties

Charging power and current (DC charging)

Type of charging current	DC
Charging current	325 A DC (With cooled HPC vehicle charging connector)
Charging power	325 kW
Rated voltage	1000 V

Charging power and current (DC charging in Boost Mode)

Type of charging current	DC Boost Mode
Charging current	> 500 A DC
Charging power	> 500 kW
Rated voltage	1000 V
Note	The specifications refer to charging in Boost Mode and are dependent on ambient conditions. For further details, see the packing slip in the download area.

Pin assignment (Power contacts)

Note on the connection method	Crimp connection, cannot be disconnected
Number	3 (PE, DC+, DC-)
Rated voltage	1000 V DC
Rated current	325 A DC (With non-cooled vehicle charging connector)

Pin assignment (Signal contacts)

Note on the connection method	Crimp connection, cannot be disconnected
Type of signal transmission	Pulse width modulation with modulated Powerline communication in accordance with ISO/IEC 15118 / DIN SPEC 70121
Number	2 (CP, PP)
Rated voltage	30 V AC
Rated current	2 A
Coding	4.7 kΩ (between PE and PP)
Insulation resistance	> 200 MΩ

Locking actuator

CHARX T2HBI24-DC375-2,0C2 - Vehicle charging inlet



1720109

<https://www.phoenixcontact.com/gb/products/1720109>

Locking actuator	24 V, 4-pos. Right position
Possible power supply range at the motor	22 V ... 26 V
Maximum voltage for locking detection	30 V
Typical motor current for locking	0.05 A
Reverse current of the motor	max. 0.5 A
Max. dwell time with reverse current	1 s
Recommended adaptation time	600 ms
Pause time after entry or exit path	3 s
Service life insertion cycles	> 10000 load cycles
Lock recognition	available
Mechanical emergency release	available
Ambient temperature (operation)	-30 °C ... 50 °C

Temperature sensors (Pt 1000)

Sensor type	Pt 1000
Standards/regulations	DIN EN 60751
Attachment point	2 sensors for the DC contacts
Recommended measured current	≤ 1 mA ($U_{max} = 16$ V DC)
Coefficient	3850 ppm/K
Ambient temperature	-40 °C ... 130 °C

Dimensions

Vehicle charging inlet

Width	108 mm
Height	140.25 mm
Depth	143.5 mm

Bore dimensions

Width	117.65 mm
Height	90 mm
Depth	117.65 mm

Material specifications

Color (Housing)	black (9005)
Color (Mating face)	black (9005)
Material (Housing)	Plastic
Material (Contact surface)	Silver

Cable/line

Cable length	2 m
Cable type	Single wires

Single-core wires for DC

Cable length	2 m
--------------	-----

CHARX T2HBI24-DC375-2,0C2 - Vehicle charging inlet



1720109

<https://www.phoenixcontact.com/gb/products/1720109>

Cable structure	2 x 120 mm ²
Single wire, material	Silicone
Single wire, color	OG
External cable diameter	23.00 mm -0.8 mm

Single-core wire for PE

Cable length	2 m
Cable structure	1 x 25 mm ²
Single wire, material	Silicone
Single wire, color	GN/YE
External cable diameter	8.60 mm ±0.1 mm

Single-core wires for locking actuator

Cable length	0.5 m
Cable structure	4 x 0.5 mm ²
Single wire, material	PVC
Single wire, color	BU/RD, BU/GN, BU/YE, BU/BN
External cable diameter	1.60 mm ±0.20 mm
Cable resistance	≤ 37.1 Ω/m

Single-core wires for Pt 1000 temperature sensors

Cable length	1 m
Cable structure	3 x 0.5 mm ²
Single wire, material	PVC
Single wire, color	BN GN YE
External cable diameter	1.60 mm ±0.20 mm
Cable resistance	≤ 37.1 Ω/m

Single-core wires for communication

Cable length	1 m
Cable structure	2 x 0.5 mm ²
Single wire, material	PVC
Single wire, color	BK WH
External cable diameter	1.60 mm ±0.20 mm
Cable resistance	≤ 37.1 Ω/m

Mechanical properties

Mechanical data

Insertion/withdrawal cycles	> 10000
Insertion force	< 100 N
Withdrawal force	< 100 N

CHARX T2HBI24-DC375-2,0C2 - Vehicle charging inlet



1720109

<https://www.phoenixcontact.com/gb/products/1720109>

Environmental and real-life conditions

Ambient conditions

Degree of protection (Vehicle charging inlet)	IP6K7
Degree of protection (Locking actuator)	IP5K4
Degree of protection (Front area)	IP6K9K
Ambient temperature (operation)	-40 °C ... 40 °C (60°C, maximum (current reduction required, observe the DC contact temperature limit value of 90°C))
Ambient temperature (storage/transport)	-40 °C ... 85 °C
Altitude	4000 m (above sea level)

Standards and regulations

Standards

Standards/regulations	IEC 62196-1
	IEC 62196-2
	IEC 62196-3

Mounting

Mounting type	Front and rear mounting (0 to 90 degree frontal inclination possible)
Mounting hole diameter	6.70 mm (ø)
Fixing screws	M6
Screws included in the scope of delivery	none

CHARX T2HBI24-DC375-2,0C2 - Vehicle charging inlet



1720109

<https://www.phoenixcontact.com/gb/products/1720109>

Drawings

Dimensional drawing

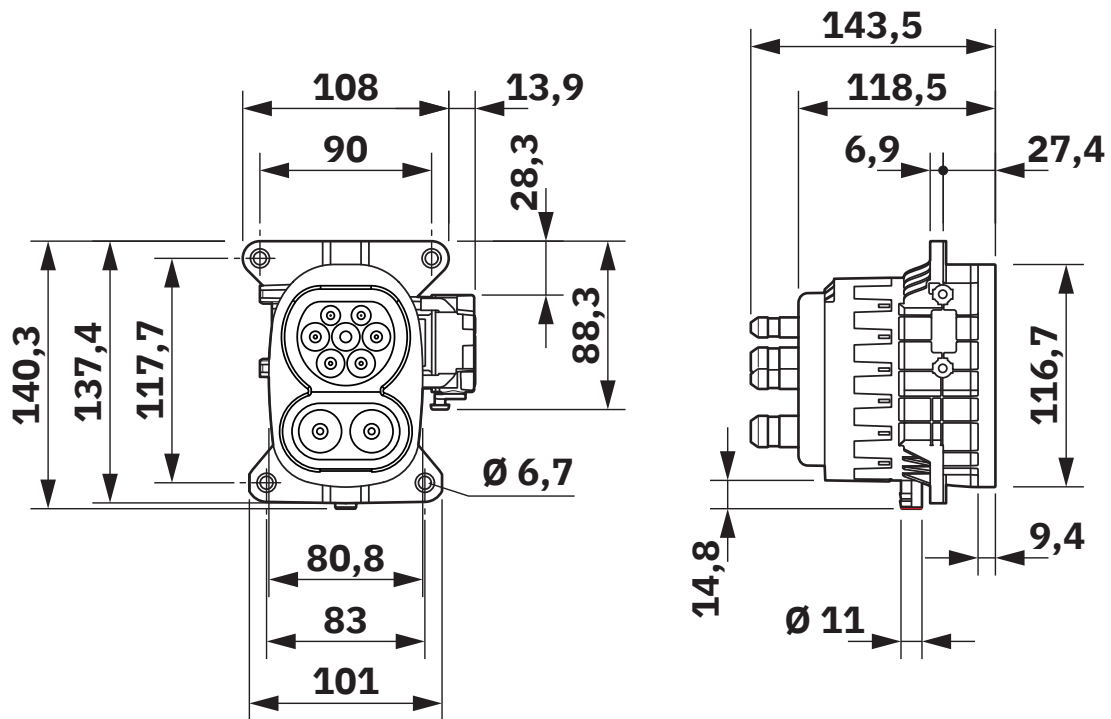

Dimensional drawing

Dimensional drawing

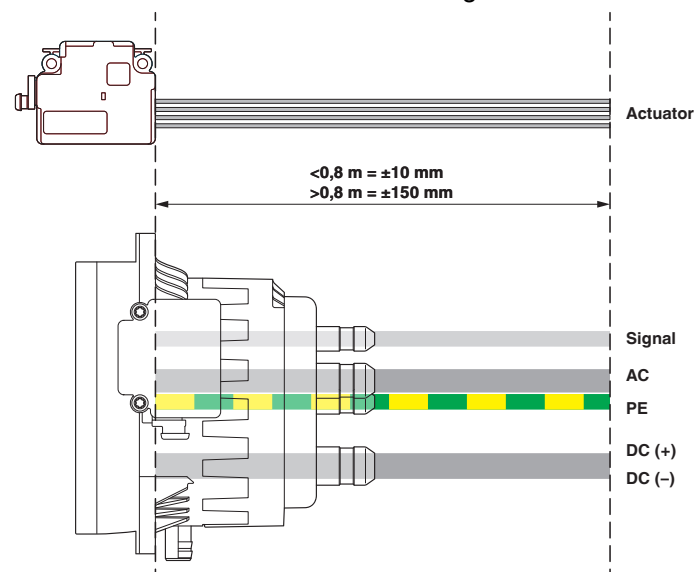

Reference points for measuring the line length

CHARX T2HBI24-DC375-2,0C2 - Vehicle charging inlet

1720109

<https://www.phoenixcontact.com/gb/products/1720109>

Connection diagram

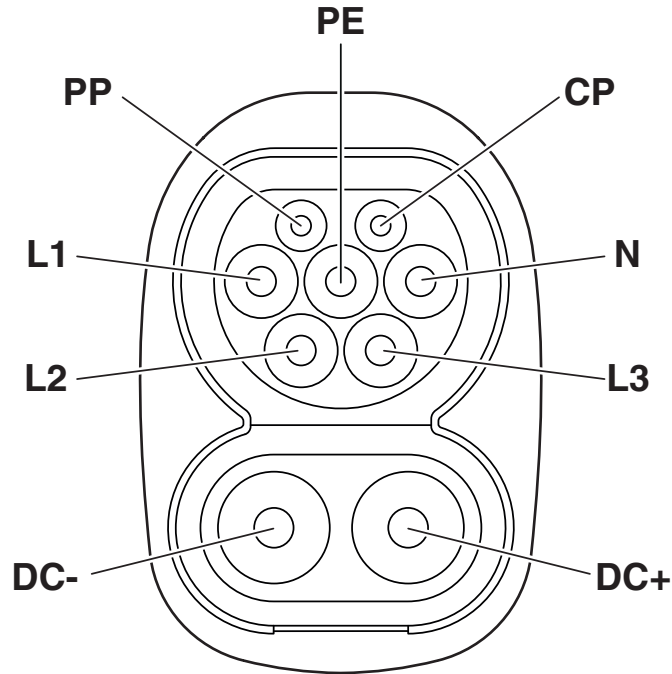

Pin assignment of vehicle charging inlets

Connection diagram

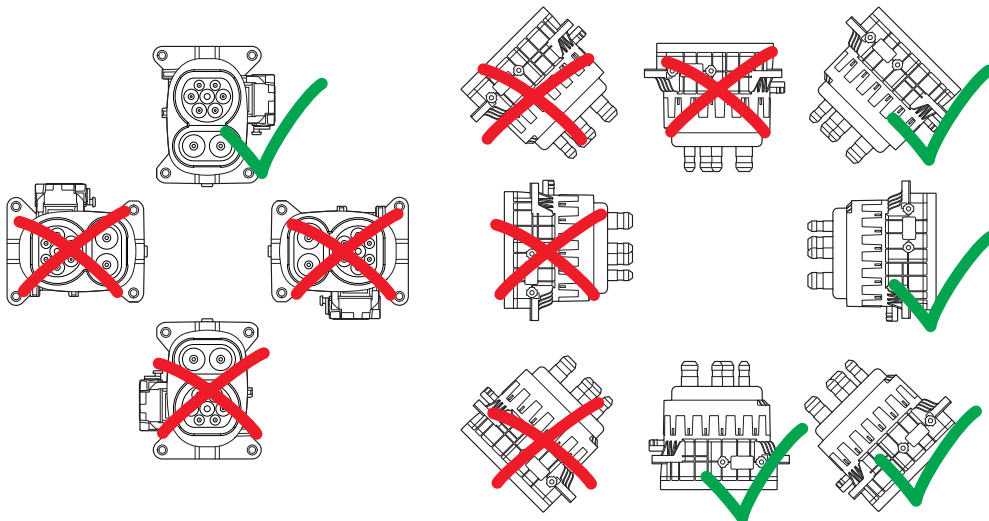

Installation positions

CHARX T2HBI24-DC375-2,0C2 - Vehicle charging inlet

1720109

<https://www.phoenixcontact.com/gb/products/1720109>



Detection for Vehicle Connector



The Combined Charging System (CCS) principle - standard-compliant charging system for electric vehicles, which supports both conventional AC charging and fast DC charging. Both Vehicle Connectors fit into the CCS Vehicle Inlet.

CHARX T2HBI24-DC375-2,0C2 - Vehicle charging inlet

1720109

<https://www.phoenixcontact.com/gb/products/1720109>

Schematic diagram



Operating instructions

CHARX T2HBI24-DC375-2,0C2 - Vehicle charging inlet



1720109

<https://www.phoenixcontact.com/gb/products/1720109>

Schematic diagram

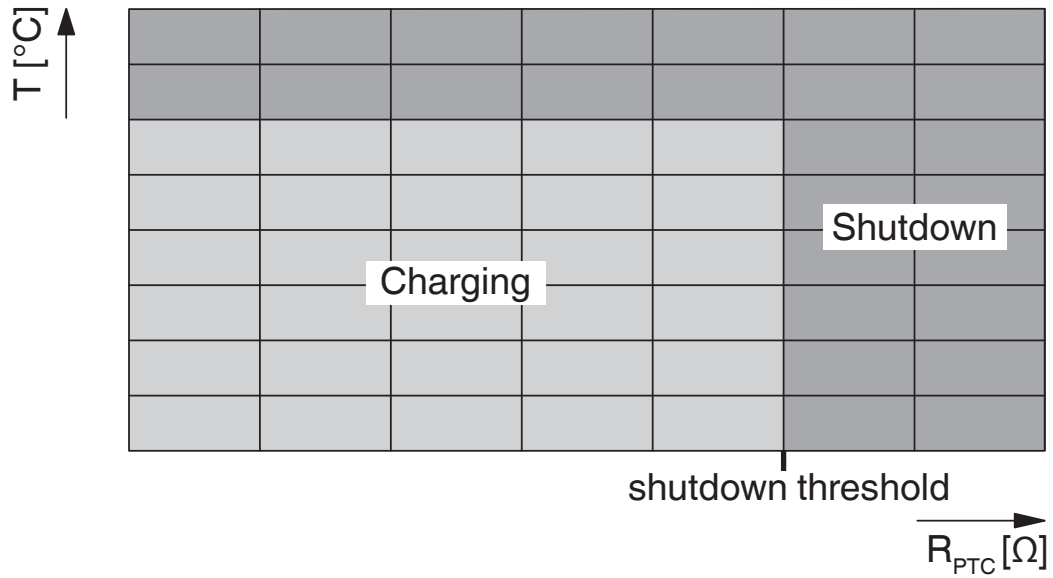

Temperature sensor technology resistance range at AC contacts

CHARX T2HBI24-DC375-2,0C2 - Vehicle charging inlet

1720109

<https://www.phoenixcontact.com/gb/products/1720109>



Locking states of the locking actuator

1720109

<https://www.phoenixcontact.com/gb/products/1720109>

Diagram



Pt 1000 characteristic curve at an ambient temperature of 25°C for temperature measurement at the DC contacts

Block diagram

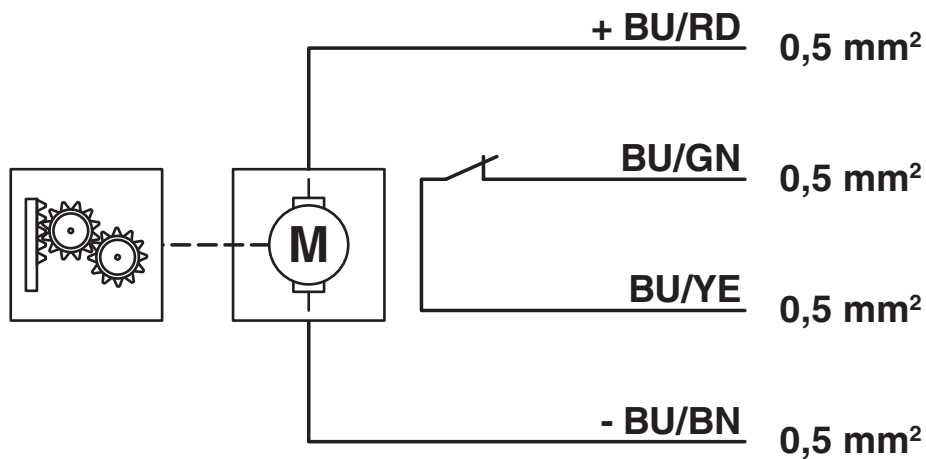

Block diagram of the locking actuator

CHARX T2HBI24-DC375-2,0C2 - Vehicle charging inlet



1720109

<https://www.phoenixcontact.com/gb/products/1720109>

Classifications

ECLASS

ECLASS-13.0	27144706
ECLASS-15.0	27144706

ETIM

ETIM 9.0	EC002898
----------	----------

UNSPSC

UNSPSC 21.0	39121800
-------------	----------

CHARX T2HBI24-DC375-2,0C2 - Vehicle charging inlet



1720109

<https://www.phoenixcontact.com/gb/products/1720109>

Environmental product compliance

EU RoHS

Fulfills EU RoHS substance requirements	Yes
Exemption	7(c)-I

China RoHS

Environment friendly use period (EFUP)	EFUP-50
	An article-related China RoHS declaration table can be found in the download area for the respective article under "Manufacturer declaration". For all articles with EFUP-E, no China RoHS declaration table issued and required.

EU REACH SVHC

REACH candidate substance (CAS No.)	2-ethylhexyl 10-ethyl-4,4-dioctyl-7-oxo-8-oxa-3,5-dithia-4-stannatetradecanoate (DOTE)(CAS: 15571-58-1)
	6,6'-di-tert-butyl-2,2'-methylenedi-p-cresol(CAS: 119-47-1)

EF3.1 Climate Change

CO2e kg	65.39 kg CO2e
---------	---------------

CHARX T2HBI24-DC375-2,0C2 - Vehicle charging inlet



1720109

<https://www.phoenixcontact.com/gb/products/1720109>

Accessories

CHARX T2HBI-DC-COVER SET - Protective cap

1793961

<https://www.phoenixcontact.com/gb/products/1793961>



CHARX connect universal, DC CCS Typ 2, Protective cap, Accessories, Plug-on assembly, housing: black, for vehicle charging inlet

CHARX T2HBI-FLAP-COMLETE - Protective cover

1778115

<https://www.phoenixcontact.com/gb/products/1778115>



CHARX connect universal, AC/DC CCS Typ 2, Protective cover, Accessories, square, M6, with status indicator via freely controllable RGB LED, with cancel charging button, for mounting on vehicle charging inlets, UNECE R61

CHARX T2HBI24-DC375-2,0C2 - Vehicle charging inlet

1720109

<https://www.phoenixcontact.com/gb/products/1720109>

CHARX T2HBI-FLAP-ESSENTIAL - Protective cover

1778119

<https://www.phoenixcontact.com/gb/products/1778119>



CHARX connect universal, AC/DC CCS Typ 2, Protective cover, Accessories, square, M6, for mounting on vehicle charging inlets, UNECE R61

CHARX T2HI-ELOCK12V - Locking

1331532

<https://www.phoenixcontact.com/gb/products/1331532>



CHARX connect universal, Type 2, Locking, Accessories, Single wires, length: 1 m, locking actuator: 12 V, 4-pos., for mounting on vehicle charging inlets, IEC 61851-1

CHARX T2HBI24-DC375-2,0C2 - Vehicle charging inlet



1720109

<https://www.phoenixcontact.com/gb/products/1720109>

CHARX T2HI-ELOCK24V - Locking

1331524

<https://www.phoenixcontact.com/gb/products/1331524>

CHARX connect universal, Type 2, Locking, Accessories, Single wires, length: 1 m, locking actuator: 24 V, 4-pos., for mounting on vehicle charging inlets, IEC 61851-1



Phoenix Contact 2026 © - all rights reserved

<https://www.phoenixcontact.com>

PHOENIX CONTACT Ltd

Halesfield 13, Telford

Shropshire, TF7 4PG

01952 681700

info@phoenixcontact.co.uk